

MCN Monitoring and Control Network

***GPIO
General Purpose Input/Output Module
Hardware Reference Manual***

S2-61286-106

***Note:
Switch settings vary
depending upon the system.***

***Be sure to verify switch settings
before installation***

***Be sure to set the rotary address switches to the
proper addresses before installing the system.***



FCC Statement

This equipment has been tested and found to comply with the limits for a Class A digital device, pursuant to Part 15 of the FCC Rules. These limits are designed to provide reasonable protection against harmful interference when the equipment is operated in a commercial environment. This equipment generates, uses, and can radiate radio frequency energy and, if not installed and used in accordance with the instruction manual, may cause harmful interference to radio communications. Operation of this equipment in a residential area is likely to cause harmful interference in which case the user will be required to correct the interference at his own expense.

Warning: Changes or modifications to this unit not expressly approved by the party responsible for compliance could void the user's authority to operate the equipment.

DOC Statement

This Class A digital apparatus meets all requirements of the Canadian Interference-Causing Equipment Regulations.

Cet appareil numérique de la classe A respecte toutes les exigences du Règlement sur le matériel brouilleur du Canada.

Computer Software Copyrights

This manual describes products which include copyrighted CTI Products, Inc. computer programs in semiconductor memory. CTI Products, Inc. reserves all rights for these programs, including the exclusive right to copy or reproduce the copyrighted computer programs in any form. No copyrighted computer program contained in products described in this manual may be copied, reproduced, decompiled, disassembled, or reversed engineered in any manner without express written permission of CTI Products, Inc. The purchase of products from CTI Products, Inc. shall not be deemed to grant either directly or by implication, estoppel, or otherwise, any license under the copyrights, patents, or patent applications of CTI Products, Inc., except for the normal non-exclusive, royalty fee license to use that arises by operation of law in the sale of the product.

Information contained in this document is subject to change without notice and does not represent a commitment on the part of CTI Products, Inc.

No part of this manual may be reproduced or transmitted in any form or by any means, electronic or mechanical, including photocopying and recording, for any purpose without the written permission of CTI Products, Inc.

Copyright 1995-2009 CTI Products, Inc. All rights reserved.

MCN, CIB, GPIO and MCNRCD are trademarks of CTI Products, Inc. Other trademarks referenced are properties of their respective owners.

CTI Products, Inc.

1211 W. Sharon Rd.
Cincinnati, OH 45240

Phone: (513) 595-5900. (8:30 to 5:00 Eastern)

TABLE OF CONTENTS

1. INTRODUCTION.....	5
1.1 MODELS	5
1.2 MODULE USAGE IN A SYSTEM.....	6
1.3 REFERENCE DOCUMENTS	6
2. SPECIFICATIONS.....	7
3. INPUTS & OUTPUTS.....	8
3.1 SOLID STATE RELAY OPTION	9
3.2 MECHANICAL RELAY OPTION	9
3.3 MAGNETICALLY-LATCHED RELAY OPTION	9
4. INDICATORS	10
4.1 INPUT AND OUTPUT LEDs.....	10
4.2 PWR, ERR, ACT LEDs	10
5. OPTION SWITCHES & JUMPERS	11
5.1 GROUP & MODULE SWITCHES.....	11
5.2 OPTION SWITCHES.....	11
5.2.1 <i>Initializing the Relays</i>	12
5.3 JUMPER OPTIONS.....	13
6. CONNECTORS	14
6.1 NETWORK CONNECTORS	14
6.2 DC IN CONNECTOR.....	14
6.3 J1 50-PIN CONNECTOR PINOUT	15
6.3.1 <i>Optically-Isolated 12 Input Option</i>	16
6.3.2 <i>Solid-State "A" (Form A) 12 Output Option</i>	17
6.3.3 <i>Electro-Mechanical "C" (Form C) 8 Output Option</i>	18
6.3.4 <i>Magnetically-Latched "L" (Form C) 8 Output Option</i>	20
7. MOUNTING.....	21
8. TROUBLESHOOTING	22
9. WARRANTY.....	24

Manual Revisions:

- S2-61286-100 Original Release.
- S2-61286-105 Updated Opto Input voltage range and I/O connector pins 25 & 50.
- S2-61286-105 Updated Pin out information to add more clarity concerning the different types of modules. Page 10

1. Introduction

The General Purpose Input/Output Modules are part of CTI Products' MCN™ Monitoring and Control Network. Versions are available with combinations of opto-isolated inputs, SSR (Solid-State Relay) outputs, or mechanical relay outputs. They can be used to monitor and control a wide range of devices at remote sites, including:

- Generators
- Doors / Intrusion alarms
- Door Locks
- Gate Controls
- Power Fail
- Temperature Alarms
- Microwave / T1 Link Status

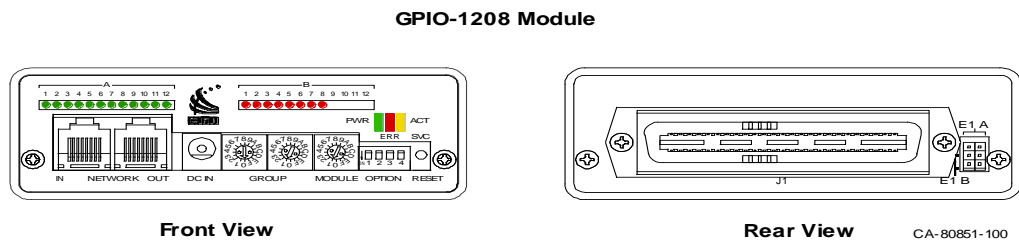

Figure 1 – GPIO Module

1.1 Models

GPIO Modules are available in standard configurations listed in the following Models table. Contact CTI Products for additional variations.

CTI Part Number	Model	Opto-Isolated Inputs	SSR Outputs (Form A)	E-M Relay Outputs (Form C)	Magnetically Latched Relay Outputs (Form C)
S2-61281	GPI-12	12			
S2-61282	GPI-24	24			
S2-61283	GPO-12A		12		
S2-61284	GPO-24A		24		
S2-61285	GPIO-1212A	12	12		
S2-61299	GPIO-1208C	12		8	
S2-61363	GPO-16C			16	
S2-61426	GPIO-1208L	12			8
S2-61437	GPIO-16L				16

Table 1 – Standard Models

Inputs are optically isolated, accept voltage inputs of 5 - 48 VDC or 12 - 24 VAC (nominal), and can be monitored with a PC running the MCNRCD Software.

Outputs are controlled from a PC running the MCNRCD Software, and can be either latching or momentary.

1.2 Module Usage in a System

This section describes the operation of the GPIO module in an MCN display system.

Input Monitoring and Output Control

Off/on status from devices connected to inputs of the GPIO is sent to a MCN User Interface Module over the MCN network. The User Interface Module (such as the HIB-IP) then transfers the status to the PC running MCNRCD Software. The MCNRCD Software displays the device status information on the PC monitor.

Likewise, off/on states of devices connected to GPIO outputs can be controlled from the MCNRCD Software.

System Example

Figure 2 shows an example system to monitor and control equipment I/O using GPIO modules. In this system, HIB-IP modules are used to “tunnel” these I/O signals over an IP network, for display on a PC.

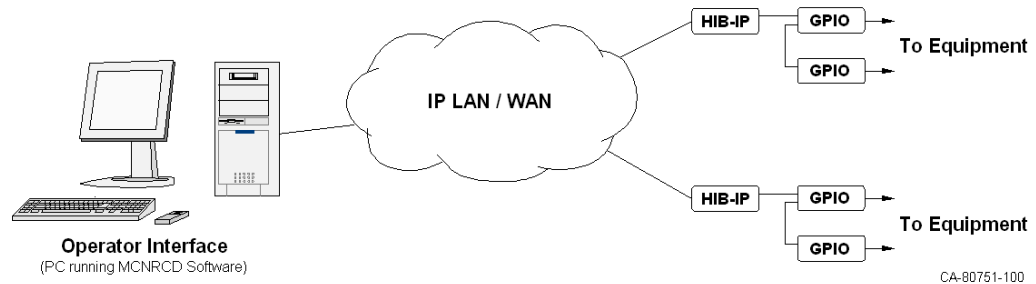

Figure 2 – GPIO in an MCN System

1.3 Reference Documents

1. Monitoring and Control Network System Manual
Part Number S2-60425

2. Specifications

Size	MCN Size A 5.5" x 4.2" x 1.5" (140 x 107 x 38 mm)
Weight	19 oz (540 gm)
Temperature	0 – 50 °C
Humidity	10 - 95% non-condensing
Module Power	+12 to +30 VDC (2W max) +18 to +30 VDC for MCN Daisy Chain power output
Inputs	Optically Isolated DC : On: 5 to 48 V (Nominal) (56V maximum) Off: 0.5V maximum AC: On: 12 – 24V (Nominal) (40V maximum) Off: 0.35V maximum RMS 0.50V maximum peak Input Impedance: 5K Ohms nominal
Output Options	
Solid State Relay	SPST (Form A) Optically Isolated 24 VAC/VDC, 1 A Max. Resistive
Electro-Mechanical Relay	SPDT (Form C) 48 VDC (60VDC max) 1 A Max. Resistive 24 VAC (40VAC max) 1 A Max. Resistive
Magnetically Latched Relay	SPDT (Form C) 48 VDC (60VDC max) 1 A Max. Resistive 24 VAC (40VAC max) 1 A Max. Resistive
Inputs and Outputs per Module	See Table 1 above (Section 1.1)
Indicators	One LED for each input & output
Equipment Connector	50 Pin Telco style, female
Network Connectors	(2) RJ-45 (1 in, 1 out)
Maximum Network Segment	4000 ft. without repeaters
Maximum Interface Modules	16 per network segment (Larger, multi-segment systems can be custom-configured.)
Network Cabling	4 Pair, CAT 5 UTP

Table 2 – GPIO Module Specifications

3. Inputs & Outputs

Figure 3 shows the equivalent input and output circuits of the GPIO.

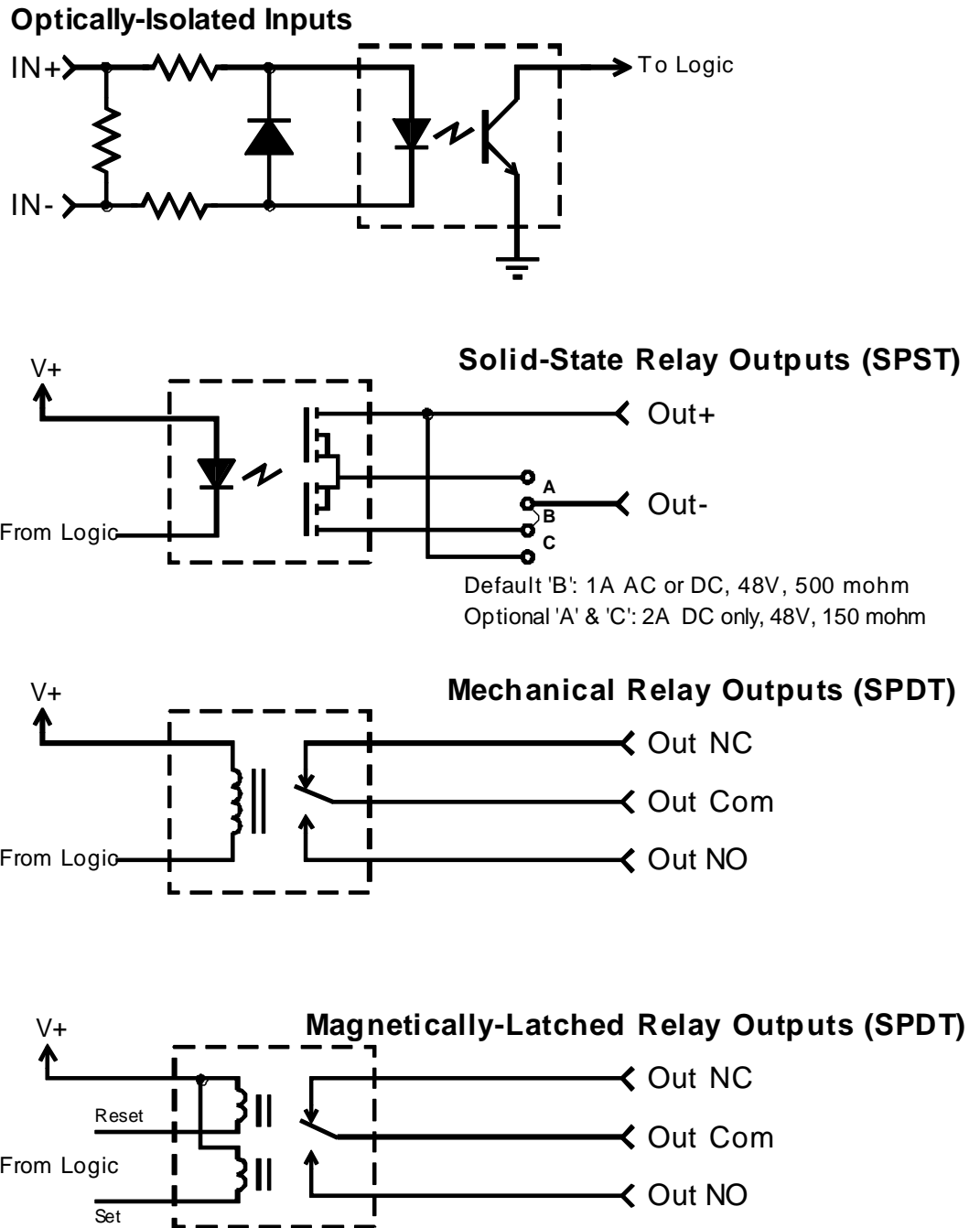

Figure 3 - I/O Equivalent Circuits

3.1 Solid State Relay Option

The default setting for Solid State Relay output current is 1 A maximum, resistive. For this setting, the relay on-resistance is 500 m-ohms. For DC loads only, an internal jumper setting is available to allow 1.5 A maximum, with an on-resistance of 150 m-ohms.

The maximum current stated above is for resistive loads only. For inductive loads, the maximum current must be de-rated.

Jumper settings for Solid State Relay maximum load selection are listed in the following table.

Load Type	Voltage (max.)	Current (max.)	On-Resistance	Jumper(s)
AC or DC	24V	1 A	500 m-ohms	B
Hi DC	24V	1.5 A	150 m-ohms	A & C

Table 3 – Loading Selection for Solid State Relay Option

3.2 Mechanical Relay Option

The Maximum Current rating of 1A listed in Table 2 is for resistive loads only. For inductive loads, the maximum current must be de-rated.

3.3 Magnetically-Latched Relay Option

When these relays are changed to the Set mode, the Normally Open contact will close, and the Normally Closed contact will open. When changed to the Reset mode, the Normally Open contact will open, and the Normally Closed contact will close.

Magnetically-latched relays will hold their state even when the power to the GPIO module is off.

The Maximum Current rating of 1A listed in Table 2 is for resistive loads only. For inductive loads, the maximum current must be de-rated.

4. Indicators

4.1 Input and Output LEDs

The GPIO has LEDs to display the status of all installed inputs and outputs. Status LEDs for inputs are green. Status LEDs for outputs are red. The following shows a GPIO module configured with 12 inputs (on the left) and eight outputs (on the right). LEDs will be lit when the input or output is active.

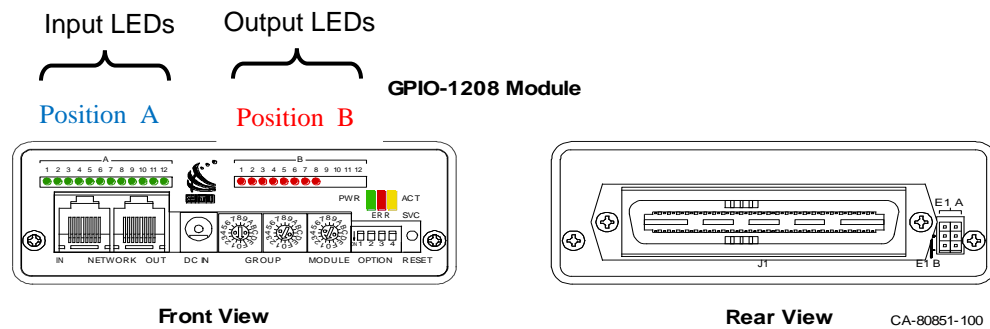

Figure 4 – Location of Indicators and Setup Switches

4.2 PWR, ERR, ACT LEDs

The GPIO has three additional LED indicators on the front panel.

PWR	Continuously lit:	Sufficient power is present.
	Blinking:	Voltage is low.
ERR	1 Blink:	Group:Module set to FF:F (Invalid address)
	Continuously lit:	Other error (hardware or software)
ACT	Lit:	Connected to a PC running MCNRCD software

5. Option Switches & Jumpers

Addressing and option switches are provided for module configuration. The module must be power cycled or reset after these switches are set so that the options will take effect. Press the Reset toggle switch down to reset the module.

5.1 Group & Module Switches

The Group and Module rotary selector switches are used to set the node address during module installation. Each module must have a unique Group:Module address. Refer to the *Monitor and Control Network System Manual*, S2-60425, for details about address planning or the *Custom System Configuration* documentation for pre-assigned addresses if your system is a Custom Engineered system.

SWITCH	DESCRIPTION	DEFAULT
GROUP	Unit Address setting (00-FE) refer to the MCN System Manual	00
MODULE	Unit Address setting (0-F) refer to the MCN System Manual	0

Table 4 – Group & Module Switches

5.2 Option Switches

This section applies only if magnetically-latched relays are installed in the GPIO.

The Option switches allow the technician to pre-set any magnetically-latched relay outputs that are installed in the GPIO module.

OPTION SWITCH	DESCRIPTION	Notes	Default
1	Not used		Down
2	Not used		Down
3	Reset Initial State	See Table 6	Down
4	Reset Initialize Enable	See Table 6	Down

Table 5 - Option Switches

Option Switches 3 & 4 are used to select the initial state at power-up and reset. Use the Default setting for Solid State Relay (-A) and non-latched (-C) outputs:

SW3	SW4	Initial State on Power Up or Reset	Default
Down	Down	Do not re-initialize. Use last stored state.	X
Up	Down	Do not re-initialize. Use last stored state.	
Down	Up	Initialize to OFF	
Up	Up	Initialize to ON	

Table 6 – Initial State on Reset

5.2.1 Initializing the Relays

Magnetically-Latched relays in the GPIO will retain their state when power is off. The initial state of relays after power-up will be all ON or all OFF.

If the relays come up in a random pattern when the power is initially applied, it is probably because the relays were jarred during transport or installation.

To initialize the relays to the ON state:

1. Set switches as follows:
 3 Up 4 Up.
2. Press the Reset Switch down and wait for 2 seconds.
3. The magnetically-latched relays should go into the ON State.
All the output LEDs should be ON.
4. Set switches as follows:
 3 Down 4 Down
5. Press the Reset Switch down and wait for 2 seconds.
6. The magnetically-latched relays should STAY in the ON State.
All the output LEDs should be ON.

To initialize the relays to the OFF state:

1. Set switches as follows:
 3 Down 4 Up.
2. Press the Reset Switch down and wait for 2 seconds.
3. The magnetically-latched relays should go into the OFF State.
All the output LEDs should be OFF.
4. Set switches as follows:
 3 Down 4 Down
5. Press the Reset Switch down and wait for 2 seconds.
6. The magnetically-latched relays should STAY in the OFF State.
All the output LEDs should be OFF.

This procedure assumes that you want the magnetically-latched relays to maintain the last state on power-up. If you want the magnetically-latched relays to always start up in the ON State or OFF State, use the appropriate switch settings from

*Table 6 in steps 4 above.

5.3 Jumper Options

Figure 5 shows the jumper options on the rear of the unit. Note that neither of these jumpers is connected internally on the GPIO, and therefore, has no usage.

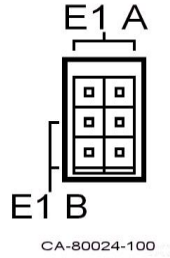
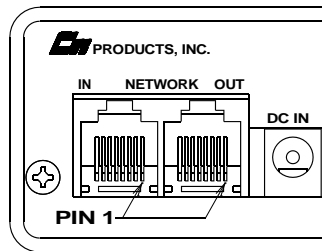

Figure 5 - Jumper Options

6. Connectors

6.1 Network Connectors

The **NETWORK IN/OUT** ports on the front of the GPIO are used to connect the GPIO with other MCN modules. These ports carry both the network data signals as well as DC power for power distribution with other modules. Table 7 gives the pinout for these connectors. Figure 6 shows the location of pin 1 for each port.



CA-80068-100

Figure 6 - Network IN/OUT Ports

Pin	Function
1	DATA +
2	DATA -
3	+ POWER
4	No Connect
5	No Connect
6	- POWER
7	- POWER
8	+ POWER

Table 7 - Network Connector Pinout

6.2 DC IN Connector

The **DC IN** port provides the primary power connection to the module. Power is distributed through the **NETWORK OUT** connector to provide power to the **NETWORK IN** connector of a subsequent MCN unit. Each power supply can power one to four units. See *Monitoring and Control Network System Manual S2-60425* for complete details of connections to the network and DC IN connectors.

6.3 J1 50-Pin Connector Pinout

Connector J1 provides access to the discrete I/O signals. The following tables show the connector pinout in Punch-Block order.

An I/O option (such as 12I, 12O, 8C, or 8L) can be installed in either the 'A' Option Position of the GPIO module, or the 'B' Option Position, or both. In GPIO modules, the Input board is always in the A (left) position.

- The first 12 pairs of J1 are dedicated to Option Position A (left)
- The second 12 pairs of J1 are dedicated to Option Position B (right)
- The last pair (pins 50 & 25) is chassis ground.

6.3.1 Optically-Isolated 24 Input Option

Showing both (left) Position (A) and (right) Position (B) on the **GPI24** module.

J1 Pin	Option Position	Signal	Front Panel LED
26	A	In A1 +	A1
1	A	In A1 -	
27	A	In A2 +	A2
2	A	In A2 -	
28	A	In A3 +	A3
3	A	In A3 -	
29	A	In A4 +	A4
4	A	In A4 -	
30	A	In A5 +	A5
5	A	In A5 -	
31	A	In A6 +	A6
6	A	In A6 -	
32	A	In A7 +	A7
7	A	In A7 -	
33	A	In A8 +	A8
8	A	In A8 -	
34	A	In A9 +	A9
9	A	In A9 -	
35	A	In A10 +	A10
10	A	In A10 -	
36	A	In A11 +	A11
11	A	In A11 -	
37	A	In A12 +	A12
12	A	In A12 -	
38	B	In B1 +	B1
13	B	In B1 -	
39	B	In B2 +	B2
14	B	In B2 -	
40	B	In B3 +	B3
15	B	In B3 -	
41	B	In B4 +	B4
16	B	In B4 -	
42	B	In B5 +	B5
17	B	In B5 -	
43	B	In B6 +	B6
18	B	In B6 -	
44	B	In B7 +	B7
19	B	In B7 -	
45	B	In B8 +	B8
20	B	In B8 -	
46	B	In B9 +	B9
21	B	In B9 -	
47	B	In B10 +	B10
22	B	In B10 -	
48	B	In B11 +	B11
23	B	In B11 -	
49	B	In B12 +	B12
24	B	In B12 -	
50		Chassis Gnd	
25		Chassis Gnd	

6.3.2 Solid-State "A" (Form A) 24 Output Option

Showing both (left) Position (A) and (right) Position (B) on the **GPI24** module.

J1 Pin	Option Position	Signal	Front Panel LED
26	A	Out A1 +	A1
1	A	Out A1 -	
27	A	Out A2 +	A2
2	A	Out A2 -	
28	A	Out A3 +	A3
3	A	Out A3 -	
29	A	Out A4 +	A4
4	A	Out A4 -	
30	A	Out A5 +	A5
5	A	Out A5 -	
31	A	Out A6 +	A6
6	A	Out A6 -	
32	A	Out A7 +	A7
7	A	Out A7 -	
33	A	Out A8 +	A8
8	A	Out A8 -	
34	A	Out A9 +	A9
9	A	Out A9 -	
35	A	Out A10 +	A10
10	A	Out A10 -	
36	A	Out A11 +	A11
11	A	Out A11 -	
37	A	Out A12 +	A12
12	A	Out A12 -	
38	B	Out B1 +	B1
13	B	Out B1 -	
39	B	Out B2 +	B2
14	B	Out B2 -	
40	B	Out B3 +	B3
15	B	Out B3 -	
41	B	Out B4 +	B4
16	B	Out B4 -	
42	B	Out B5 +	B5
17	B	Out B5 -	
43	B	Out B6 +	B6
18	B	Out B6 -	
44	B	Out B7 +	B7
19	B	Out B7 -	
45	B	Out B8 +	B8
20	B	Out B8 -	
46	B	Out B9 +	B9
21	B	Out B9 -	
47	B	Out B10 +	B10
22	B	Out B10 -	
48	B	Out B11 +	B11
23	B	Out B11 -	
49	B	Out B12 +	B12
24	B	Out B12 -	
50		Chassis Gnd	
25		Chassis Gnd	

6.3.3 Solid-State "A" (Form A) 12 Output Option

Showing both (left) Position (A) and (right) Position (B) on the **GPI24** module.

J1 Pin	Option Position	Signal	Front Panel LED
26	A	In A1 +	A1
1	A	In A1 -	
27	A	In A2 +	A2
2	A	In A2 -	
28	A	In A3 +	A3
3	A	In A3 -	
29	A	In A4 +	A4
4	A	In A4 -	
30	A	In A5 +	A5
5	A	In A5 -	
31	A	In A6 +	A6
6	A	In A6 -	
32	A	In A7 +	A7
7	A	In A7 -	
33	A	In A8 +	A8
8	A	In A8 -	
34	A	In A9 +	A9
9	A	In A9 -	
35	A	In A10 +	A10
10	A	In A10 -	
36	A	In A11 +	A11
11	A	In A11 -	
37	A	In A12 +	A12
12	A	In A12 -	
38	B	Out B1 +	B1
13	B	Out B1 -	
39	B	Out B2 +	B2
14	B	Out B2 -	
40	B	Out B3 +	B3
15	B	Out B3 -	
41	B	Out B4 +	B4
16	B	Out B4 -	
42	B	Out B5 +	B5
17	B	Out B5 -	
43	B	Out B6 +	B6
18	B	Out B6 -	
44	B	Out B7 +	B7
19	B	Out B7 -	
45	B	Out B8 +	B8
20	B	Out B8 -	
46	B	Out B9 +	B9
21	B	Out B9 -	
47	B	Out B10 +	B10
22	B	Out B10 -	
48	B	Out B11 +	B11
23	B	Out B11 -	
49	B	Out B12 +	B12
24	B	Out B12 -	
50		Chassis Gnd	
25		Chassis Gnd	

6.3.4 Electro-Mechanical "C" (Form C) 8 Output Option

Showing both (left) Position (A) and (right) Position (B) on the **GPIO 1208 C** module.

J1 Pin	Option Position	Signal	Alternate Tip-Ring Signal Pairs	Front Panel LED
26	A	In A1 +	A1	26
1	A	In A1 -		1
27	A	In A2 +	A2	27
2	A	In A2 -		2
28	A	In A3 +	A3	28
3	A	In A3 -		3
29	A	In A4 +	A4	29
4	A	In A4 -		4
30	A	In A5 +	A5	30
5	A	In A5 -		5
31	A	In A6 +	A6	31
6	A	In A6 -		6
32	A	In A7 +	A7	32
7	A	In A7 -		7
33	A	In A8 +	A8	33
8	A	In A8 -		8
34	A	In A9 +	A9	34
9	A	In A9 -		9
35	A	In A10 +	A10	35
10	A	In A10 -		10
36	A	In A11 +	A11	36
11	A	In A11 -		11
37	A	In A12 +	A12	37
12	A	In A12 -		12
38	B	RY B1 Com	Pair B1 Com Tip	
13	B	RY B2 Com	Pair B2 Com Ring	
39	B	RY B1 NO	Pair B1 NO Tip	B1
14	B	RY B2 NO	Pair B2 NO Ring	
40	B	RY B1 NC	Pair B1 NC Tip	B2
15	B	RY B2 NC	Pair B2 NC Ring	
41	B	RY B3 Com	Pair B3 Com Tip	
16	B	RY B4 Com	Pair B4 Com Ring	
42	B	RY B3 NO	Pair B3 NO Tip	B3
17	B	RY B4 NO	Pair B4 NO Ring	
43	B	RY B3 NC	Pair B3 NC Tip	B4
18	B	RY B4 NC	Pair B4 NC Ring	
44	B	RY B5 Com	Pair B5 Com Tip	
19	B	RY B6 Com	Pair B6 Com Ring	
45	B	RY B5 NO	Pair B5 NO Tip	B5
20	B	RY B6 NO	Pair B6 NO Ring	
46	B	RY B5 NC	Pair B5 NC Tip	B6
21	B	RY B6 NC	Pair B6 NC Ring	
47	B	RY B7 Com	Pair B7 Com Tip	
22	B	RY B8 Com	Pair B8 Com Ring	
48	B	RY B7 NO	Pair B7 NO Tip	B7
23	B	RY B8 NO	Pair B8 NO Ring	
49	B	RY B7 NC	Pair B7 NC Tip	B8
24	B	RY B8 NC	Pair B8 NC Ring	
50		Chassis Gnd		
25		Chassis Gnd		

6.3.5 Magnetically-Latched "L" (Form C) 8 Output 12 Input Option

Showing both (left) Position (A) and (right) Position (B) on the **GPIO 1208 C/L** module.

J1 Pin	Option Position	Signal	Alternate Tip-Ring Signal Pairs	Front Panel LED
26	A	In A1 +	A1	26
1	A	In A1 -		1
27	A	In A2 +	A2	27
2	A	In A2 -		2
28	A	In A3 +	A3	28
3	A	In A3 -		3
29	A	In A4 +	A4	29
4	A	In A4 -		4
30	A	In A5 +	A5	30
5	A	In A5 -		5
31	A	In A6 +	A6	31
6	A	In A6 -		6
32	A	In A7 +	A7	32
7	A	In A7 -		7
33	A	In A8 +	A8	33
8	A	In A8 -		8
34	A	In A9 +	A9	34
9	A	In A9 -		9
35	A	In A10 +	A10	35
10	A	In A10 -		10
36	A	In A11 +	A11	36
11	A	In A11 -		11
37	A	In A12 +	A12	37
12	A	In A12 -		12

38	B	RY B1 Com	Pair B1 Com Tip	
13	B	RY B2 Com	Pair B2 Com Ring	
39	B	RY B1 NO	Pair B1 NO Tip	B1
14	B	RY B2 NO	Pair B2 NO Ring	
40	B	RY B1 NC	Pair B1 NC Tip	B2
15	B	RY B2 NC	Pair B2 NC Ring	
41	B	RY B3 Com	Pair B3 Com Tip	
16	B	RY B4 Com	Pair B4 Com Ring	
42	B	RY B3 NO	Pair B3 NO Tip	B3
17	B	RY B4 NO	Pair B4 NO Ring	
43	B	RY B3 NC	Pair B3 NC Tip	B4
18	B	RY B4 NC	Pair B4 NC Ring	
44	B	RY B5 Com	Pair B5 Com Tip	
19	B	RY B6 Com	Pair B6 Com Ring	
45	B	RY B5 NO	Pair B5 NO Tip	B5
20	B	RY B6 NO	Pair B6 NO Ring	
46	B	RY B5 NC	Pair B5 NC Tip	B6
21	B	RY B6 NC	Pair B6 NC Ring	
47	B	RY B7 Com	Pair B7 Com Tip	
22	B	RY B8 Com	Pair B8 Com Ring	
48	B	RY B7 NO	Pair B7 NO Tip	B7
23	B	RY B8 NO	Pair B8 NO Ring	
49	B	RY B7 NC	Pair B7 NC Tip	B8
24	B	RY B8 NC	Pair B8 NC Ring	

50		Chassis Gnd		
25		Chassis Gnd		

7. Mounting

Various mounting kits are available to mount the GPIO module.

Mounting Kits	
Rack Mount - 4 A size modules 1 Rack Unit (1.75") High	S2-60435
Rack Mount - 2 A size modules plus 1 B size module 1 Rack Unit (1.75") High (Used to mount 2 GPIOs and 1 EXB module.)	S2-60443

Refer to *Monitoring and Control Network System Manual S2-60425, Mounting Options* section, for physical details about mounting the GPIO module.

8. Troubleshooting

This table is a list of troubleshooting tips specific to the GPIO module. For additional troubleshooting tips, refer to the troubleshooting section found in the *Monitoring and Control Network System Manual S2-60425*.

Due to the high percentage of surface-mount components, the GPIO is treated as a field replaceable unit. If any system problems are the result of a malfunctioning GPIO module, the entire unit must be replaced and returned for repair.

PROBLEM	CAUSE
The PWR LED flashes	The input DC voltage is low. There may be too many modules in line. There is a voltage drop in each module and the downstream modules will each see a lower DC voltage.
The ERR LED flashes once	The Group & Module switches are set to FF:F. This is an invalid address. Set the Group & Module switches to the proper address for your system and press the Reset switch down.
The ERR LED is on continuously	Internal hardware or firmware error. Call the factory for an RMA.
Input LEDs are stuck on	An input may be stuck active. Remove the 50-pin I/O connector. If the input LED goes off, the problem is external to the GPIO. If the input LED remains stuck on, there is an internal problem in the unit. Call the factory for an RMA.
Output LEDs for Magnetically-Latched relays come up in a random state on initial power-up	The Magnetically-Latched relays may have been jarred during transport. Initialize the relays as described in section 5.2.1, <i>Initializing the Relays</i> above. If this problem persists and is not due to mechanical shock on the relays, it indicates an internal problem. Call the factory for an RMA.

PROBLEM	CAUSE
The last state of Magnetically-Latched relays is not held on power-up or reset	<p>Check Option Switch 4. If it is up, the GPIO will initialize this state based upon Switch 3. See <i>Table 6 – Initial State on Reset</i>.</p> <p>Set Switches 3 & 4 Down and reset the unit.</p>
The last state of Magnetically-Latched relays is held on power-up, but a known state is required	<p>Check Option Switch 4. If it is down, the GPIO will power-up using the previous state. If you need it to power-up in a known state (OFF or ON), set the proper state on Switches 3 & 4 and reset the unit. See "<i>Table 6 – Initial State on Reset</i>" for details.</p>
The PC shows the receivers from this GPIO module as "Offline".	<p>Check the MCN cabling. Also, check that the GPIO address and the address listed for the module in the PC database match.</p> <p>In an engineered system (with routers and/or EXB modules) the PC may have an improper address or the module might be installed on the wrong MCN sub-network. Check the custom system documentation for the proper settings and connections.</p>
The ACT LED is off	<p>This is an indication that a PC is not communicating with this module. See the "Offline" problem above.</p>

9. Warranty

Standard Limited Hardware Warranty

LIMITED WARRANTY. Equipment manufactured by CTI Products, Inc. is warranted to be free from defects in material and workmanship for a period of ONE (1) YEAR from date of shipment to original purchaser. Under this warranty, our obligation is limited to repairing or replacing any equipment proved to be defective by our inspection within one year of sale to the original purchaser. This warranty shall not apply to equipment which has been repaired outside our plant in any way, so as to, in the judgment of CTI Products, Inc. affect its stability or reliability, nor which has been operated in a manner exceeding its specifications, nor which has been altered, defaced, or damaged by lightning.

CUSTOMER REMEDIES. In the event of a defect, malfunction, or failure to conform to specifications established by the seller during the period shown, the customer shall call CTI Products, Inc. to obtain a Return Authorization Number and return the product or module, shipping and insurance prepaid. CTI Products, Inc., will then at its option, either repair or replace the product or module and return it, shipping prepaid, or refund the purchase price thereof. On-site labor at the purchaser's location is not included in this warranty.

EQUIPMENT NOT MANUFACTURED BY CTI Products, Inc. Equipment not manufactured by CTI Products, Inc. is excluded from this warranty, but is subject to the warranty provided by its manufacturer, a copy of which will be supplied to you upon specific written request.

NO OTHER WARRANTIES. The foregoing constitutes the sole and exclusive remedy of the buyer and exclusive liability of CTI Products, Inc., AND IS IN LIEU OF ANY AND ALL OTHER WARRANTIES EXPRESSED OR IMPLIED OR STATUTORY AS TO MERCHANTABILITY, FITNESS FOR PURPOSE SOLD, DESCRIPTION, QUALITY, PRODUCTIVENESS OR ANY OTHER MATTER.

NO LIABILITY FOR CONSEQUENTIAL DAMAGES. WITHOUT LIMITING THE FOREGOING, IN NO EVENT SHALL CTI PRODUCTS, INC. OR ITS SUPPLIERS BE LIABLE FOR ANY DAMAGES WHATSOEVER (INCLUDING, WITHOUT LIMITATION, SPECIAL, INCIDENTAL OR CONSEQUENTIAL DAMAGES OR FOR LOSS OF BUSINESS PROFITS, BUSINESS INTERRUPTION, LOSS OF BUSINESS INFORMATION, OR OTHER PECUNIARY LOSS) ARISING OUT OF THE USE OF OR INABILITY TO USE CTI PRODUCTS, INC. EQUIPMENT BY PURCHASER OR OTHER THIRD PARTY, WHETHER UNDER THEORY OF CONTRACT, TORT (INCLUDING NEGLIGENCE), INDEMNITY, PRODUCT LIABILITY OR OTHERWISE, EVEN IF CTI PRODUCTS, INC. HAS BEEN ADVISED OF THE POSSIBILITY OF SUCH DAMAGES OR LOSSES. IN NO EVENT SHALL CTI PRODUCTS, INC.'S LIABILITY EXCEED THE TOTAL AMOUNT PAID BY PURCHASER FOR THE EQUIPMENT GIVING RISE TO SUCH LIABILITY

