

***MCN Monitoring and Control Network
Comparator Display System***

***Input/Output Control Module
IOB
Hardware Reference Manual***

S2-60630-105

NOTE: This module must be configured before being installed in your system. Refer to section 4 for information about the module configuration.

FCC Statement

This equipment has been tested and found to comply with the limits for a Class A digital device, pursuant to Part 15 of the FCC Rules. These limits are designed to provide reasonable protection against harmful interference when the equipment is operated in a commercial environment. This equipment generates, uses, and can radiate radio frequency energy and, if not installed and used in accordance with the instruction manual, may cause harmful interference to radio communications. Operation of this equipment in a residential area is likely to cause harmful interference in which case the user will be required to correct the interference at his own expense.

Warning: Changes or modifications to this unit not expressly approved by the party responsible for compliance could void the user's authority to operate the equipment.

DOC Statement

This Class A digital apparatus meets all requirements of the Canadian Interference-Causing Equipment Regulations.

Cet appareil numérique de la classe A respecte toutes les exigences du Règlement sur le matériel brouilleur du Canada.

Computer Software Copyrights

This manual describes products which include copyrighted CTI Products, Inc. computer programs in semiconductor memory. CTI Products, Inc. reserves all rights for these programs, including the exclusive right to copy or reproduce the copyrighted computer programs in any form. No copyrighted computer program contained in products described in this manual may be copied, reproduced, decompiled, disassembled, or reversed engineered in any manner without express written permission of CTI Products, Inc. The purchase of products from CTI Products, Inc. shall not be deemed to grant either directly or by implication, estoppel, or otherwise, any license under the copyrights, patents, or patent applications of CTI Products, Inc., except for the normal non-exclusive, royalty fee license to use that arises by operation of law in the sale of the product.

Information contained in this document is subject to change without notice and does not represent a commitment on the part of CTI Products, Inc.

No part of this manual may be reproduced or transmitted in any form or by any means, electronic or mechanical, including photocopying and recording, for any purpose without the written permission of CTI Products, Inc.

Copyright 1996, 1997, CTI Products, Inc. All rights reserved.

MCN is a trademark of CTI Products, Inc. Other trademarks referenced are properties of their respective owners.



IOB Hardware Reference CTI Products, Inc.

Standard Limited Hardware Warranty

LIMITED WARRANTY. Equipment manufactured by CTI Products, Inc. is warranted to be free from defects in material and workmanship for a period of ONE (1) YEAR from date of shipment to original purchaser. Under this warranty, our obligation is limited to repairing or replacing any equipment proved to be defective by our inspection within one year of sale to the original purchaser. This warranty shall not apply to equipment which has been repaired outside our plant in any way, so as to, in the judgment of CTI Products, Inc. affect its stability or reliability, nor which has been operated in a manner exceeding its specifications, nor which has been altered, defaced, or damaged by lightning.

CUSTOMER REMEDIES. In the event of a defect, malfunction, or failure to conform to specifications established by the seller during the period shown, the customer shall call CTI Products, Inc. to obtain a Return Authorization Number and return the product or module, shipping and insurance prepaid. CTI Products, Inc., will then at its option, either repair or replace the product or module and return it, shipping prepaid, or refund the purchase price thereof. On-site labor at the purchaser's location is not included in this warranty.

EQUIPMENT NOT MANUFACTURED BY CTI Products, Inc. Equipment not manufactured by CTI Products, Inc. is excluded from this warranty, but is subject to the warranty provided by its manufacturer, a copy of which will be supplied to you upon specific written request.

NO OTHER WARRANTIES. The foregoing constitutes the sole and exclusive remedy of the buyer and exclusive liability of CTI Products, Inc., AND IS IN LIEU OF ANY AND ALL OTHER WARRANTIES EXPRESSED OR IMPLIED OR STATUTORY AS TO MERCHANTABILITY, FITNESS FOR PURPOSE SOLD, DESCRIPTION, QUALITY, PRODUCTIVENESS OR ANY OTHER MATTER.

NO LIABILITY FOR CONSEQUENTIAL DAMAGES. WITHOUT LIMITING THE FOREGOING, IN NO EVENT SHALL CTI PRODUCTS, INC. OR ITS SUPPLIERS BE LIABLE FOR ANY DAMAGES WHATSOEVER (INCLUDING, WITHOUT LIMITATION, SPECIAL, INCIDENTAL OR CONSEQUENTIAL DAMAGES OR FOR LOSS OF BUSINESS PROFITS, BUSINESS INTERRUPTION, LOSS OF BUSINESS INFORMATION, OR OTHER PECUNIARY LOSS) ARISING OUT OF THE USE OF OR INABILITY TO USE CTI PRODUCTS, INC. EQUIPMENT BY PURCHASER OR OTHER THIRD PARTY, WHETHER UNDER THEORY OF CONTRACT, TORT (INCLUDING NEGLIGENCE), INDEMNITY, PRODUCT LIABILITY OR OTHERWISE, EVEN IF CTI PRODUCTS, INC. HAS BEEN ADVISED OF THE POSSIBILITY OF SUCH DAMAGES OR LOSSES. IN NO EVENT SHALL CTI PRODUCTS, INC.'S, LIABILITY EXCEED THE TOTAL AMOUNT PAID BY PURCHASER FOR THE EQUIPMENT GIVING RISE TO SUCH LIABILITY.

CTI Products, Inc.
1211 W. Sharon Rd.
Cincinnati, OH 45240

If you have questions about the MCN system, call us at:
(513) 595-5900. (8:30 to 5:00 Eastern)

1. INTRODUCTION.....	1
1.1 REFERENCE DOCUMENTS	1
2. SPECIFICATIONS.....	2
3. THEORY OF OPERATION.....	4
3.1 CONTROLLING THE I/O	4
3.1.1 <i>Input Monitoring - I/O Groups and I/O Bits</i>	4
3.1.2 <i>Output Control</i>	7
3.2 MODE 1 - GENERAL PURPOSE I/O - 16 OUTPUTS	8
3.3 MODE 2 - TWO SETS OF 1 OF 4 SELECT OUTPUT	8
3.4 MODE 3 - ONE SET OF 1 OF 4 SELECT OUTPUTS	9
3.5 MODE 4 - ONE SET OF 1 OF 8 SELECT OUTPUTS	9
3.6 CUSTOM STATUS TEXT SUB-CATEGORIES	10
4. OPTION SWITCHES AND JUMPERS	14
5. CONNECTORS.....	17
6. MOUNTING.....	20
7. SYSTEM EXAMPLES	21
7.1 GENERAL PURPOSE I/O EXAMPLE	21
7.2 ONE OF FOUR SELECT I/O EXAMPLE	23
7.3 INVERTED SELECT A EXAMPLE	25
7.4 SUB-CATEGORY EXAMPLE.....	26
8. TROUBLESHOOTING	28

1. Introduction

The Input/Output Control (IOB) is a member of the Monitoring and Control Network (MCN™) family of auxiliary modules. Hardware specifications, system examples, and configuration information are provided in this manual.

The IOB module connects I/O devices (such as relays) to the MCN network. The IOB is used with a User Interface Module (such as a HIB) to create an I/O control system.

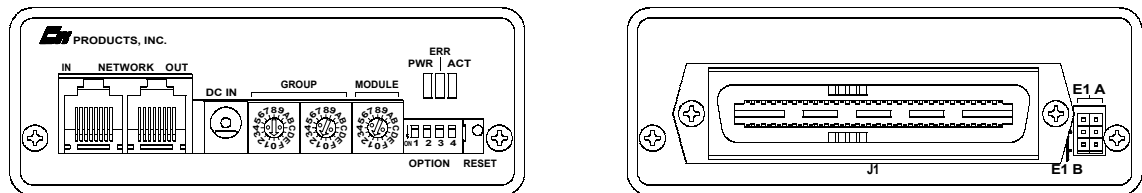

CA-80023-100

Figure 1 - IOB Front and Rear View

1.1 Reference Documents

1. Monitoring and Control Network System Manual
Part Number S2-60425
2. Monitoring and Control Network Remote Comparator Display Software
Part Number S2-60428

2. Specifications

Size	5.5" x 4.2" x 1.5" (140 x 107 x 38 mm)
Weight	16 oz (455 gm)
Temperature	0 - 50 °C
Humidity	10 - 95% non-condensing
Module Power	10 - 32 Vdc / 2 Watts max.
Number of Input Points	32 max (depending on the operating mode)
Number of Output Points	16 max (depending on the operating mode)
Open Circuit Voltage (all I/O pins) jumper E1B removed jumper E1B installed	+13.8 Vdc nominal +5 Vdc nominal
Input Voltage (Input pins)	-0.6 to 30 Vdc (max)
Input Current (Input pins): jumper E1B removed (Vin = 0 Vdc) jumper E1B installed (Vin = 0 Vdc)	-720 µA max (source) -270 µA max (source)
Output Saturation Voltage (Output pins) with Iout = 100 mA	550 mV
Output Pin Current (Output pins)	150 mA max per individual pin (sink) 100 mA max per pin if all outputs are ON.
Power Dissipation	2 Watts Nominal
Input/Output Connection	50 pin Telco style
Network Connector	(2) RJ-45 (1 in, 1 out)
Safety Approvals	UL 1950 CSA 1950 EN 60950-1992
Emissions Compliance	FCC Part 15, Class A DOC Class A EN55022
Susceptibility Compliance	IEC 801-2 IEC 801-3 IEC 801-4 EN50082-1

Table 1 - Module Specifications

Figure 2 shows the equivalent circuits of the IOB I/O pins. The pull-up voltage V_p by jumper E1B, located on the rear of the module.

- $V_p = 13.8$ Vdc with jumper E1B out
- $V_p = 5.0$ Vdc with jumper E1B in

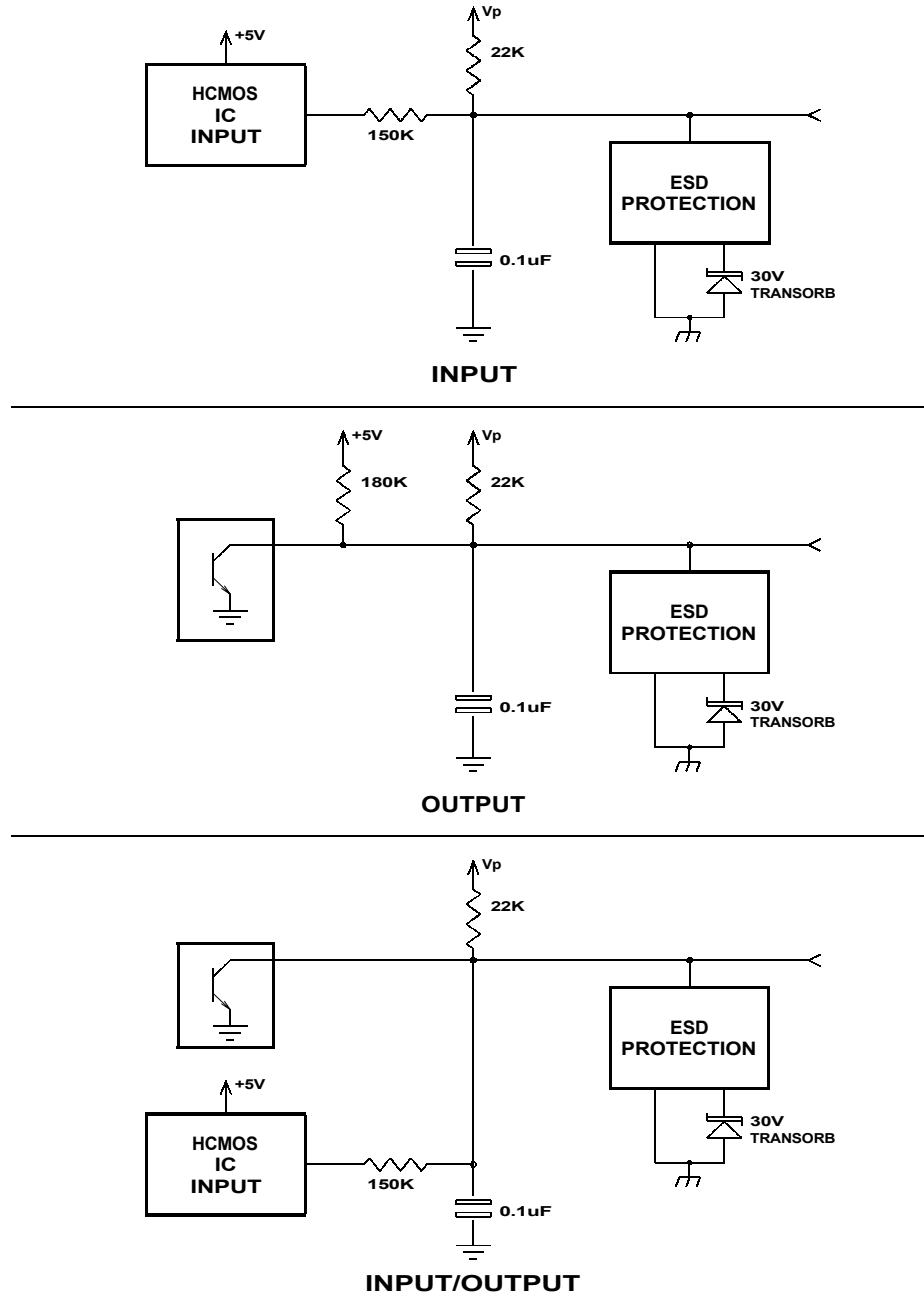

CA-80043-100

Figure 2 - I/O Equivalent Circuit

3. Theory of Operation

This section describes the operation of the IOB module in an I/O control system. This module can operate in one of four different modes:

I/O Group	Mode 1	Mode 2	Mode 3	Mode 4
1	Independent I/O	1 of 4 Select # 1	1 of 4 Select	1 of 8 Select
2				
3				
4				
5		1 of 4 Select # 2	Independent I/O	
6				
7				
8				

The operating mode is set using the OPTION switches on the module's front panel. Refer to section 4 for a description of the mode setting switches and section 5 for a pinout of the IOB's I/O connector. The functions of the I/O connector pins on the rear of the module change depending on the IOB's operating mode.

Each operating mode is discussed in the following sections.

3.1 Controlling the I/O

The MCN HIB module, along with the MCNRCD Remote Comparator Display program, provides a PC based user interface for the IOB module. Output points on the IOB can be controlled by either the PC keyboard or mouse. Input points can be monitored on the screen.

In order to have the MCNRCD software display meaningful I/O status messages, custom status text categories and custom status messages must be created for your specific I/O application (see the appendix titled *Changing Status Message Text* in the Monitoring and Control Network Remote Comparator Display Software Manual (reference 2) for details about creating custom status messages). These custom status messages are defined in the file MCNRCD.CFG.

Section 7 provides a number of examples that show how to customize the MCNRCD display for an IOB module.

3.1.1 Input Monitoring - I/O Groups and I/O Bits

With the MCNRCD software, a single display position on the screen does not represent a single I/O point. Instead, each display position represents the state of four I/O points. We refer to the four I/O points that make up a screen display position as an I/O group (this is similar to the 4 bits, Vote Rx, Disable, and Fail associated with a receiver in comparator applications using a CIB module).

An IOB has 8 I/O groups (similar to the 8 receivers per CIB module). Since each I/O group is represented by four I/O points, a maximum of 32 I/O points can be displayed per IOB. When configuring your MCNRCD screens for IOB modules, know that each I/O group is related to an Rx # in the MCNRCD and MCNCFG software. I/O group 1 is the same as Rx # 1 and so on through I/O group 8 is the same as Rx # 8.

The basic IOB module is setup as 8 I/O groups. Each I/O group has the following 4 I/O lines:

I/O Bit #	Type	Status Byte Binary Weight	MCNRCD Input Status Signal	Output Controlled By
1	Input/Output	01 hex	VOTE	left mouse button or "V"
2	Input	04 hex	RECEIVE	N/A
3	Input/Output	10 hex	DISABLE	right mouse button or "D"
4	Input	40 hex	FAIL	N/A

Table 2 - I/O Point Binary Weight

Table 2 shows the binary weight of each I/O bit. These binary weights are summed to create the **input value** fields of the MCNRCD.CFG text definition line. This allows you to display up to 16 status message values for each I/O group (receiver) on the MCNRCD screen. All valid combinations of these binary weights must be defined by separate text definition lines (again, see the appendix titled *Changing Status Message Text* in the Monitoring and Control Network Remote Comparator Display Software Manual (reference 2) for details about creating custom status messages). Table 3 shows the possible combinations of the binary weights (in the Input Value Field column) and the I/O bit combinations for that value. A column has also been provided for you to enter the text corresponding to the input value field.

In the 1 or 4 and 1 of 8 select configurations, the output for I/O bit 3 is disabled (only the output for I/O bit 1 can be used).

In all cases, any pin not used as an output can be used as an input. Inputs can be dynamic inputs used to sense on and off conditions or can be static "selector" inputs which are permanently strapped to provide a selector function for sub-categories.

Input Value Field	Active I/O Bit Combinations	Custom Text
00	-	
01	1	
04	2	
05	2 + 1	
10	3	
11	3 + 1	
14	3 + 2	
15	3 + 2 + 1	
40	4	
41	4 + 1	
44	4 + 2	
45	4 + 2 + 1	
50	4 + 3	
51	4 + 3 + 1	
54	4 + 3 + 2	
55	4 + 3 + 2 + 1	

Table 3 - Input Value Definitions

Note: The IOB's inputs and outputs are active low. Therefore, for a I/O bit to be active, it must be pulled to ground. Also, when an output is active, it is driven low by the IOB.

3.1.2 Output Control

As stated earlier in this section, the output points of the IOB module can be controlled by both the mouse and keyboard. Table 4 shows which I/O bits are controlled by the specific mouse or keyboard buttons. To control the I/O bit, simply move the cursor over the I/O group that represents the I/O bit and click the proper mouse button or press the proper keyboard button. The IOB output point will change state. The IOB uses the input of the input/output point to automatically generate feedback to the MCNRCD software so that the new state of the output is displayed. When using a input/output point as an output, **do not** attach any circuitry that can drive the pin. The keyboard and mouse controls can be setup to provide either a latched output or a momentary output, depending upon the setting of the **VOTE=** and **DISABLE=** definition lines for the MCNRCD.CFG category you created. Refer to the appendix titled *Changing Status Message Text* in the Monitoring and Control Network Remote Comparator Display Software Manual (reference 2) for details about configuring the button control.

I/O Bit	Mouse Control	Keyboard Control
1	left button	V key
3	right button	D key

Table 4 - Output Controls

3.2 Mode 1 - General Purpose I/O - 16 Outputs

In general purpose I/O mode, the IOB module provides 16 input/output lines and 16 input only lines. Table 16 shows the pinout for this mode as well as the I/O group and I/O bit number associated with each connector pin.

3.3 Mode 2 - Two Sets of 1 of 4 Select Output

In this mode, the IOB provides two sets of 1 of 4 Select output lines and 24 input only lines. Table 16 shows the pinout for this mode as well as the I/O group and I/O bit number associated with each connector pin.

Table 5 shows how the 1 of 4 Select outputs operate, allowing only one active output in each set of 4 Select lines (A, B, C and D). Remember, the outputs are active low so the output pin for the selected output is low and the output pins of the other select outputs are high.

Select 1 or Select 2				selected output
A	B	C	D	
1	0	0	0	Select A
0	1	0	0	Select B
0	0	1	0	Select C
0	0	0	1	Select D

Table 5 - 1 of 4 Select Operation

Note: In this table, any output shown as a 0 is a high output and any output shown as a 1 is low output.

The IOB has the option to invert the Select A output so that the Select A output pin is active high and the Select B, C and D output pins are active low. This operation is shown in Table 6. The Select A invert option is selected with OPTION switch position 3 (see section 4).

Select 1 or Select 2				selected output
A	B	C	D	
0	0	0	0	Select A
1	1	0	0	Select B
1	0	1	0	Select C
1	0	0	1	Select D

Table 6 - Inverted Select A Operation

Note: In this table, any output shown as a 0 is a high output and any output shown as a 1 is low output.

This option is typically used when you need 1 of 4 relays that will operate in a fail-safe mode when the power fails. For instance, you can drive 4 DPDT relays to provide a 1 of 4 manual transmitter selection circuit. Transmitters 2 through 4 would be connected to the normally open relay contacts, while transmitter 1 would be connected to the normally closed contacts. If the power fails, the system will revert to transmitter 1.

3.4 Mode 3 - One Set of 1 of 4 Select Outputs + 8 Independent Outputs

In this mode, the IOB provides one bank of 1 of 4 Select output lines, 8 input/output lines and 20 input only lines. Table 16 shows the pinout for this mode as well as the I/O group and I/O bit number associated with each connector pin.

The first 4 I/O groups are used as 1 of 4. I/O groups 5 through 8 are independent I/Os. The operation of the first 4 I/O groups is the same as Mode 2.

3.5 Mode 4 - One Set of 1 of 8 Select Outputs

In this mode, the IOB provides a 1 of 8 Select output and 24 input only lines. Table 16 shows the pinout for this mode as well as the I/O group and I/O bit number associated with each connector pin.

Table 7 shows how the 1 of 8 Select outputs operate, allowing only one active output in each the of 8 Select lines (A through H).

Select								selected output
A	B	C	D	E	F	G	H	
1	0	0	0	0	0	0	0	Select A
0	1	0	0	0	0	0	0	Select B
0	0	1	0	0	0	0	0	Select C
0	0	0	1	0	0	0	0	Select D
0	0	0	0	1	0	0	0	Select E
0	0	0	0	0	1	0	0	Select F
0	0	0	0	0	0	1	0	Select G
0	0	0	0	0	0	0	1	Select H

Table 7 - 1 of 8 Select Operation

Note: In this table, any output shown as a 0 is a high output and any output shown as a 1 is low output.

The IOB has the option to invert the Select A output so that the Select A output pin is active high and the Select B, C and D output pins are active low. This

operation is shown in Table 8. The Select A invert option is selected with OPTION switch position 3 (see section 4).

Select								selected output
A	B	C	D	E	F	G	H	
0	0	0	0	0	0	0	0	Select A
1	1	0	0	0	0	0	0	Select B
1	0	1	0	0	0	0	0	Select C
1	0	0	1	0	0	0	0	Select D
1	0	0	0	1	0	0	0	Select E
1	0	0	0	0	1	0	0	Select F
1	0	0	0	0	0	1	0	Select G
1	0	0	0	0	0	0	1	Select H

Table 8 - Inverted Select A Operation

Note: In this table, any output shown as a 0 is a high output and any output shown as a 1 is low output.

This can be used to drive fail-safe relays as described in Mode 2.

3.6 Custom Status Text Sub-categories

It is possible to connect different types of I/O devices (like main/standby relays and lighting control) to a single IOB module. This is done by creating sub-categories within a single category in the MCNRCD.CFG file. To create a sub-category, you need to reserve one or more of the input signals in each I/O group of the IOB module for the sub-category selector. These reserved bits are then either left floating or strapped to ground to define the possible sub-categories. The appendix titled *Changing Status Message Text* in the Monitoring and Control Network Remote Comparator Display Software Manual (reference 2) has additional information about sub-categories.

When you reserve an input signal for a sub-category selector, you are also reserving the I/O bit associated with that input signal. The reserved I/O bits are then used to define the sub-categories in the MCNRCD.CFG file. The following sections show how the multiple sub-categories can be created by reserved 1, 2 or 3 I/O bits for the sub-category selector.

Section 7.4 has a system example that defines two sub-categories.

Creating Two Sub-categories

To create two sub-categories, one I/O bit must be reserved for the sub-category selector. In Table 9, I/O bit 4 has been reserved for the sub-category selector. You can see from the table that there are eight possible status messages that can be defined for each sub-category. Because I/O bit 4 has been reserved as the selector, all IOB pins that correspond to I/O bit 4 cannot be used by application circuitry.

Input Value Field	Sub-category #	Sub-category Selector I/O Bit 4	I/O Bit Combinations		
			3	2	1
00	1	0	0	0	0
01	1	0	0	0	1
04	1	0	0	1	0
05	1	0	0	1	1
10	1	0	1	0	0
11	1	0	1	0	1
14	1	0	1	1	0
15	1	0	1	1	1
40	2	1	0	0	0
41	2	1	0	0	1
44	2	1	0	1	0
45	2	1	0	1	1
50	2	1	1	0	0
51	2	1	1	0	1
54	2	1	1	1	0
55	2	1	1	1	1

Table 9 - 2 Sub-categories / 8 States

Note: In this table, any I/O bit shown as a 0 is a floating input or a high output and any I/O bit shown as a 1 is an input tied to ground or a low output.

Creating Four Sub-categories

To create four sub-categories (for four different I/O types), two I/O bits must be reserved for the sub-category selector. In Table 10, I/O bits 3 and 4 have been reserved for the sub-category selector. You can see from the table that there are four possible status messages that can be defined for each sub-category. Because I/O bits 3 and 4 have been reserved as the selector, all IOB pins that correspond to I/O bits 3 and 4 in all I/O groups cannot be used by application circuitry.

Warning: Because I/O bit 3 is used as a sub-category selector, you must make sure that the mouse and keyboard button cannot change the state of the I/O pins corresponding to I/O bit 3. Therefore, in your category definition, make sure the **DISABLE=x** line state the following:

DISABLE=O

This line will turn off the right mouse button and the 'D' keyboard key so that I/O bit 3 cannot be controlled from the keyboard.

Input Value Field	Sub-category #	Sub-category Selector I/O Bits		I/O Bit Combinations	
		4	3	2	1
00	1	0	0	0	0
01	1	0	0	0	1
04	1	0	0	1	0
05	1	0	0	1	1
10	2	0	1	0	0
11	2	0	1	0	1
14	2	0	1	1	0
15	2	0	1	1	1
40	3	1	0	0	0
41	3	1	0	0	1
44	3	1	0	1	0
45	3	1	0	1	1
50	4	1	1	0	0
51	4	1	1	0	1
54	4	1	1	1	0
55	4	1	1	1	1

Table 10 - 4 Sub-categories / 4 States

Note: In this table, any I/O bit shown as a 0 is a floating input or a high output and any I/O bit shown as a 1 is an input tied to ground or a low output.

Creating Eight Sub-categories

To create eight sub-categories, three I/O bits must be reserved for the sub-category selector. In Table 10, I/O bits 2, 3 and 4 have been reserved for the sub-category selector. You can see from the table that there are two possible status messages that can be defined for each sub-category. Because I/O bits 2, 3 and 4 have been reserved as the selector, all IOB pins that correspond to I/O bits 2, 3 and 4 cannot be used by application circuitry.

Warning: Because I/O bit 3 is used as a sub-category selector, you must make sure that the mouse and keyboard button cannot change the state of the I/O pins corresponding to I/O bit 3. Therefore, in your category definition, make sure the **DISABLE=x** line state the following:

DISABLE=O

This line will turn off the right mouse button and the 'D' keyboard key so that I/O bit 3 cannot be controlled from the keyboard.

Input Value Field	Sub-category #	Sub-category Selector I/O Bits			I/O Bit Combinations 1
		4	3	2	
00	1	0	0	0	0
01	1	0	0	0	1
04	2	0	0	1	0
05	2	0	0	1	1
10	3	0	1	0	0
11	3	0	1	0	1
14	4	0	1	1	0
15	4	0	1	1	1
40	5	1	0	0	0
41	5	1	0	0	1
44	6	1	0	1	0
45	6	1	0	1	1
50	7	1	1	0	0
51	7	1	1	0	1
54	8	1	1	1	0
55	8	1	1	1	1

Table 11 - 8 Sub-categories / 2 States

Note: In this table, any I/O bit shown as a 0 is a floating input or a high output and any I/O bit shown as a 1 is an input tied to ground or a low output.

4. Option Switches and Jumpers

Three sets of option switches are provided for module configuration. The module must be power cycled or reset after these switches are set so that the options will take effect. Table 12 describes the option switches and shows the factory defaults.

SWITCH	DESCRIPTION	DEFAULT
GROUP	Unit Address Setting refer to the MCN System Manual	00
MODULE	Unit Address Setting refer to the MCN System Manual	0
OPTION position 1	Mode Select 1 (see Table 13)	DOWN
position 2	Mode Select 2 (see Table 13)	DOWN
position 3	Select A Invert	DOWN
position 4	I/O Scan Rate Select	DOWN

Table 12 - IOB Option Switches

The Group and Module selector switches are used to set the unit address during module installation. Refer to reference 1, the Monitoring and Control Network System Manual, for details about setting these switches.

The mode select switches (OPTION switch positions 1 and 2) set the operating mode of the IOB. Refer to section 3 for a description of the various operating modes available. Table 13 provides for a description of these switches.

Option Switch Position 1	Option Switch Position 2	Mode Number	Selected Mode
DOWN	DOWN	1	General I/O
UP	DOWN	2	2 sets of 1 of 4 Select Outputs
DOWN	UP	3	1 set of 1 of 4 Select Outputs + 8 Independent Outputs
UP	UP	4	1 set of 1 of 8 Select Outputs

Table 13 - IOB Operating Mode Selector Switches

The Select A Invert switch (OPTION switch position 3) is only used when operating modes 2, 3 or 4 are selected (in mode 1, this switch is not used). The switch is defined as:

Option Switch 3	Function
DOWN	Inverted Select A Outputs (active low)
UP	Normal Select A Outputs (active high)

This switch only affects the Select A output lines. All other Select output lines are active low. Refer to section 3 for a discussion of each operating mode.

The I/O Scan Rate Select switch (OPTION switch position 4) is used to select the I/O scan rate for the IOB module. The switch is defined as:

Option Switch 4	Function
DOWN	Normal scan rate (3 times per second)
UP	Fast scan rate (10 times per second)

The default position for this switch is DOWN, selecting an I/O scan rate of 3 times per second. For special applications, you may want to increase the scan rate to the fast scan rate (10 scans of the I/O per second). This allows the IOB module to detect inputs that are changing more than 3 times per second. The disadvantage of using the fast scan rate is that the IOB module can generate more network traffic since it will transmit a network message every time it detects an input change. With the fast scan rate selected, the IOB module could generate 10 messages per second, instead of 3 messages per second when using the normal scan rate. If an IOB module is generating more than 3 messages per second, you may see overall system performance problems (such as slower system response or missed events on other MCN modules) because other MCN modules may not be able to communicate over the network as often. Therefore, if you have IOBs in your system that are set to the fast scan rate, and you begin to experience slow system response or missed events on other MCN modules, you will have to change your IOBs to normal scan rate.

Jumper Options

Figure 3 shows the configuration of the two jumper options available on the rear of the IOB. These jumpers should be installed at system installation time with power removed from the IOB.

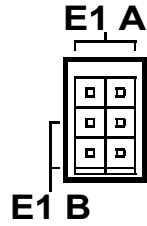

CA-80024-100

Figure 3 - Jumper Options

Jumper E1A is located across the top 2 terminals of the 6 pin terminal block. This jumper is reserved and should not be installed.

Jumper E1B is located across the left side middle and bottom terminals of the 6 pin terminal block. Set this jumper to match the needs of your I/O system.

The remaining 2 terminals of the block are unused.

Jumper	Function	Default
E1A	Reserved	OUT
E1B Vp Set	In for inputs pulled up to +5 Vdc. Out for inputs pulled up to +13.8 Vdc.	OUT

Table 14 - Jumper Definitions

Because most installations require the pull-up voltage to be +13.8 Vdc, no jumper is provided with the unit for the E1B jumper terminals. If you have an application that requires the pull-up voltage to be set to +5 Vdc, you can order an additional jumper by calling CTI Products Inc. and ordering part number 27-10351.

5. Connectors

The **NETWORK IN/OUT** ports on the front of the IOB are used to connect the IOB with other MCN modules. These ports carry both the network data signals as well as DC power for power distribution with other modules. . Table 15 gives the pinout for these connectors. Figure 4 shows the location of pin 1 for each port.

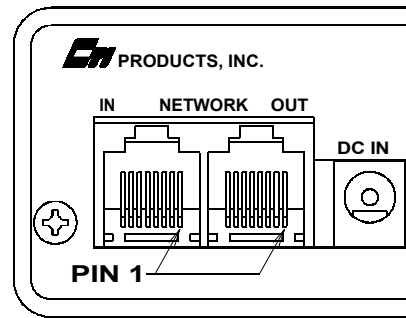

CA-80068-100

Figure 4 - Network IN/OUT Ports

Pin	Function
1	DATA +
2	DATA -
3	+ POWER
4	No Connect
5	No Connect
6	- POWER
7	- POWER
8	+ POWER

Table 15 - Network Connector Pinout

The **DC IN** port provides the primary power connection to the module. Power is distributed through the **NETWORK OUT** connector to provide power to the **NETWORK IN** connector of the MCN unit it is connected to. Each power supply can power up to four units total. See the Monitoring and Control Network System Manual (reference 1) for complete details of connections to the network and DC IN connectors.

Connector J1 provides the discrete I/O points. The pin definitions for this connector change, depending upon which operating mode the IOB module is set for. Table 16 gives the pin numbers and their definitions for each mode. The column labeled I/O bit includes, in parenthesis, the MCNRCD name associated with the bit number. Table 17 gives this same information, but the order of the IOB pin numbers matching a punch block pinout. See the appendix titled

Changing Status Message Text in the Monitoring and Control Network Remote Comparator Display Software Manual (reference 2) for more information about custom text messages.

IOB Pin #	Mode 1 (32) General Purpose I/O	Mode 2 (2) One-of-Four Select Outputs	Mode 3 (1) One-of-Four Select Outputs + 8 Independent Outputs	Mode 4 One of Eight Select Outputs	I/O Group #	I/O Bit #
21	input/output 1	Select 1A output	Select 1A output	Select 1A output	1	1 (VOTE)
46	input/output 2	Select 1B output	Select 1B output	Select 1B output	2	1 (VOTE)
15	input/output 3	Select 1C output	Select 1C output	Select 1C output	3	1 (VOTE)
40	input/output 4	Select 1D output	Select 1D output	Select 1D output	4	1 (VOTE)
9	input/output 5	Select 2A output	input/output 5	Select 1E output	5	1 (VOTE)
34	input/output 6	Select 2B output	input/output 6	Select 1F output	6	1 (VOTE)
3	input/output 7	Select 2C output	input/output 7	Select 1G output	7	1 (VOTE)
28	input/output 8	Select 2D output	input/output 8	Select 1H output	8	1 (VOTE)
22	input 1	input 1	input 1	input 1	1	2 (RECEIVE)
47	input 2	input 2	input 2	input 2	2	2 (RECEIVE)
16	input 3	input 3	input 3	input 3	3	2 (RECEIVE)
41	input 4	input 4	input 4	input 4	4	2 (RECEIVE)
10	input 5	input 5	input 5	input 5	5	2 (RECEIVE)
35	input 6	input 6	input 6	input 6	6	2 (RECEIVE)
4	input 7	input 7	input 7	input 7	7	2 (RECEIVE)
29	input 8	input 8	input 8	input 8	8	2 (RECEIVE)
20	input/output 9	input/output 9 *	input/output 9 *	input/output 9 *	1	3 (DISABLE)
45	input/output 10	input/output 10 *	input/output 10 *	input/output 10 *	2	3 (DISABLE)
14	input/output 11	input/output 11 *	input/output 11 *	input/output 11 *	3	3 (DISABLE)
39	input/output 12	input/output 12 *	input/output 12 *	input/output 12 *	4	3 (DISABLE)
8	input/output 13	input/output 13 *	input/output 13	input/output 13 *	5	3 (DISABLE)
33	input/output 14	input/output 14 *	input/output 14	input/output 14 *	6	3 (DISABLE)
2	input/output 15	input/output 15 *	input/output 15	input/output 15 *	7	3 (DISABLE)
27	input/output 16	input/output 16 *	input/output 16	input/output 16 *	8	3 (DISABLE)
23	input 9	input 9	input 9	input 9	1	4 (FAIL)
48	input 10	input 10	input 10	input 10	2	4 (FAIL)
17	input 11	input 11	input 11	input 11	3	4 (FAIL)
42	input 12	input 12	input 12	input 12	4	4 (FAIL)
11	input 13	input 13	input 13	input 13	5	4 (FAIL)
36	input 14	input 14	input 14	input 14	6	4 (FAIL)
5	input 15	input 15	input 15	input 15	7	4 (FAIL)
30	input 16	input 16	input 16	input 16	8	4 (FAIL)
1	Ground	Ground	Ground	Ground		

Table 16 - Connector J1 Pinout

* These pins are treated as “input only” when in the specific mode. The output control of these pins has been disabled.

IOB Pin	Mode 1	Mode 2	Mode 3	Mode 4	I/O Group #	I/O Bit #
26						
1	Ground	Ground	Ground	Ground		
27	input/output 16	input/output 16 *	input/output 16	input/output 16 *	8	3 (DISABLE)
2	input/output 15	input/output 15 *	input/output 15	input/output 15 *	7	3 (DISABLE)
28	input/output 8	Select 2D output	input/output 8	Select 1H output	8	1 (VOTE)
3	input/output 7	Select 2C output	input/output 7	Select 1G output	7	1 (VOTE)
29	input 8	input 8	input 8	input 8	8	2 (RECEIVE)
4	input 7	input 7	input 7	input 7	7	2 (RECEIVE)
30	input 16	input 16	input 16	input 16	8	4 (FAIL)
5	input 15	input 15	input 15	input 15	7	4 (FAIL)
31						
6						
32						
7						
33	input/output 14	input/output 14 *	input/output 14	input/output 14 *	6	3 (DISABLE)
8	input/output 13	input/output 13 *	input/output 13	input/output 13 *	5	3 (DISABLE)
34	input/output 6	Select 2B output	input/output 6	Select 1F output	6	1 (VOTE)
9	input/output 5	Select 2A output	input/output 5	Select 1E output	5	1 (VOTE)
35	input 6	input 6	input 6	input 6	6	2 (RECEIVE)
10	input 5	input 5	input 5	input 5	5	2 (RECEIVE)
36	input 14	input 14	input 14	input 14	6	4 (FAIL)
11	input 13	input 13	input 13	input 13	5	4 (FAIL)
37						
12						
38						
13						
39	input/output 12	input/output 12 *	input/output 12 *	input/output 12 *	4	3 (DISABLE)
14	input/output 11	input/output 11 *	input/output 11 *	input/output 11 *	3	3 (DISABLE)
40	input/output 4	Select 1D output	Select 1D output	Select 1D output	4	1 (VOTE)
15	input/output 3	Select 1C output	Select 1C output	Select 1C output	3	1 (VOTE)
41	input 4	input 4	input 4	input 4	4	2 (RECEIVE)
16	input 3	input 3	input 3	input 3	3	2 (RECEIVE)
42	input 12	input 12	input 12	input 12	4	4 (FAIL)
17	input 11	input 11	input 11	input 11	3	4 (FAIL)
43						
18						
44						
19						
45	input/output 10	input/output 10 *	input/output 10 *	input/output 10 *	2	3 (DISABLE)
20	input/output 9	input/output 9 *	input/output 9 *	input/output 9 *	1	3 (DISABLE)
46	input/output 2	Select 1B output	Select 1B output	Select 1B output	2	1 (VOTE)
21	input/output 1	Select 1A output	Select 1A output	Select 1A output	1	1 (VOTE)
47	input 2	input 2	input 2	input 2	2	2 (RECEIVE)
22	input 1	input 1	input 1	input 1	1	2 (RECEIVE)
48	input 10	input 10	input 10	input 10	2	4 (FAIL)
23	input 9	input 9	input 9	input 9	1	4 (FAIL)
49						
24						
50						
25						

Table 17 - Connector J1 Pinout in Punch Block Order

6. Mounting

Refer to the Monitoring and Control Network System Manual (reference 1), section *Mounting Options*, for details about mounting the IOB module.

CAUTION

Make sure that any mounting screws used to secure unit to a bracket do not protrude into the unit's enclosure more than 1/8 inches from the bottom surface of the unit.

Using a larger screw that touches the pc board inside the unit may damage the unit when it is powered. Doing so will void the unit's warranty.

7. System Examples

This section contains various examples that describe the different operating modes of the IOB module.

7.1 General Purpose I/O Example

Figure 5 shows a general purpose I/O system that is monitored from a local PC.

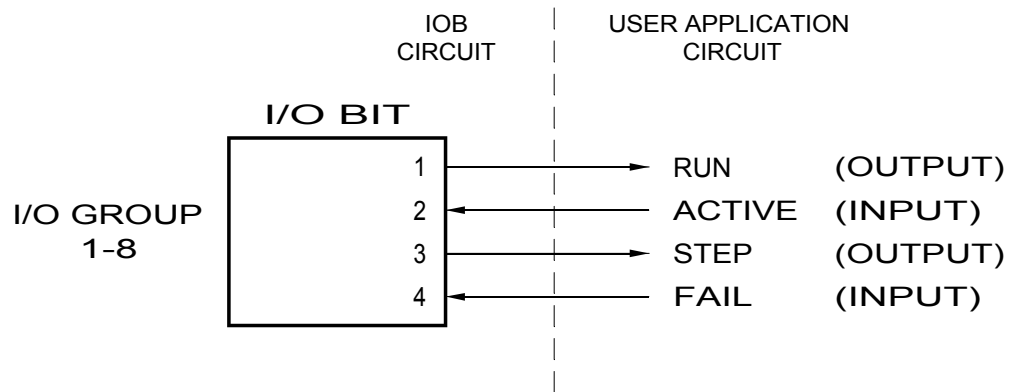

CA-80277-100

Figure 5 - I/O Group Configuration

For this application, we will need to create a custom status text category in the MCNRCD.CFG file so that the MCNRCD software can display meaningful status messages. Before editing the MCNRCD.CFG file, we need to define our custom text messages. Table 18 shows the functions for each I/O bit.

I/O Bit #	Function	Binary Weight
1	Run	01 hex
2	Active	04 hex
3	Step	10 hex
4	Fail	40 hex

Table 18 - Example System Text Definition

Next we need to create a custom text table for all possible input value field combinations. Table 19 shows the custom text messages and the corresponding input value fields.

Input Value Field	Active I/O Bit Combinations	Custom Text
00	-	
01	1	Run
04	2	Active
05	2 + 1	Run/Act
10	3	Step
11	3 + 1	Run/Step
14	3 + 2	Step/Act
15	3 + 2 + 1	Run/Act
40	4	Fail
41	4 + 1	Fail/Run
44	4 + 2	Fail
45	4 + 2 + 1	Fail/Run
50	4 + 3	Fail/Step
51	4 + 3 + 1	Fail
54	4 + 3 + 2	Fail/Step
55	4 + 3 + 2 + 1	Fail

Table 19 - Custom Text for General I/O System

From this table we can now create our custom status text category in the MCNRCD.CFG file. Refer to the appendix in the Monitoring and Control Network Remote Comparator Display Software Manual (reference 2) titled *Changing Status Message Text* for details about the format of the MCNRCD.CFG file.

7.2 One of Four Select I/O Example

Figure 6 shows an I/O system that uses the IOB in 1 of 4 Select mode. The four Select outputs are connected to relay controls and the four PTT inputs are connected to input pins of the IOB.

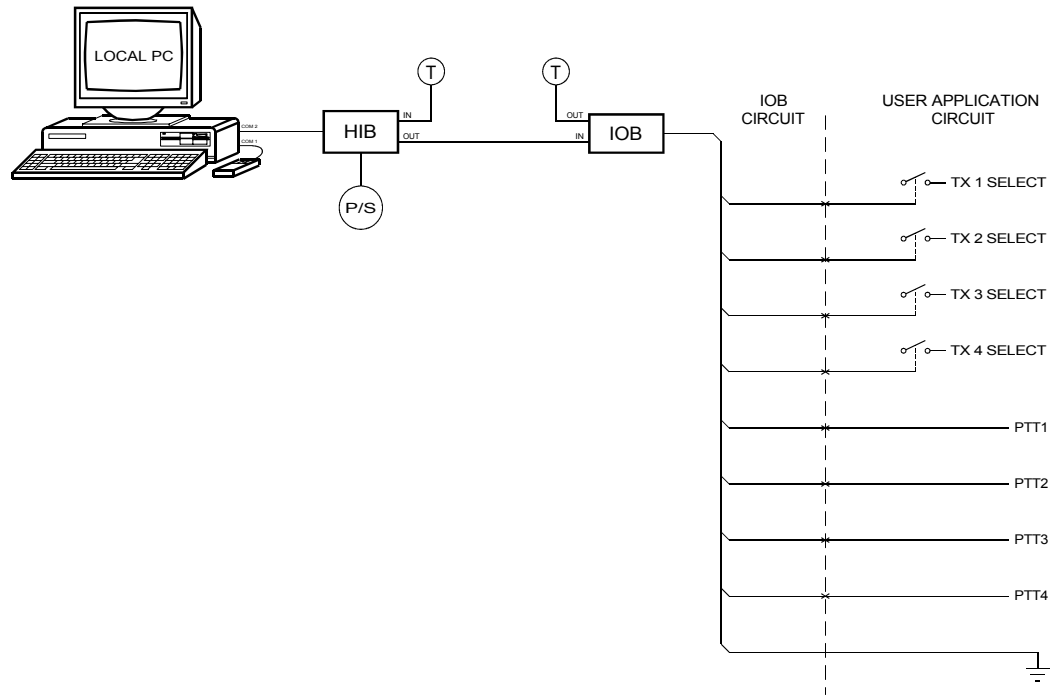

CA-80258-100

Figure 6 - 1 of 4 Select System Example

Just as in the previous example, we need to create a custom status text category for this IOB. Before creating the status text messages, we should look at how each I/O group will be configured. Figure 7 shows the I/O bit configuration for each of the four I/O groups being used.

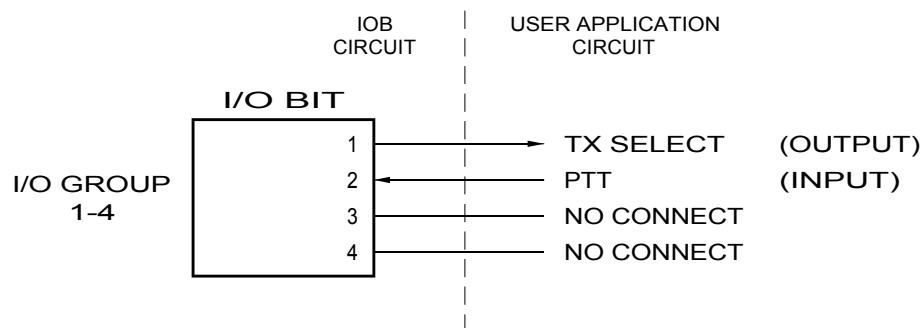

CA-80276-100

Figure 7 - 1 of 4 Select I/O Bit Configuration (Tx Select and PTT)

From the figure, you can see that relay control lines are connected to the Select 1A through D outputs of the IOB. These outputs correspond to I/O bit 1 of I/O groups 1 through 4. The PTT inputs are connected to four input lines of the IOB, which correspond to I/O group bits 2 (RECEIVE) and 4 (FAIL) of I/O groups 5 through 8.

Before editing the MCNRCD.CFG file, we need to define our custom text messages. Let's define the status messages for the active Select output line to be the text **Active** and the status messages for the active input lines to be **Tx**. Now we can create a custom text table for all possible input value field combinations. Table 20 shows the custom text messages and the corresponding input value fields.

Input Value Field	Active I/O Bit Combinations	Custom Text
00	-	
01	1	Active
04	2	Tx
05	1 + 2	Act/Tx

Table 20 - 1 of 4 Select Example Custom Text

From this table we can now create our custom status text category in the MCNRCD.CFG file. Refer to the appendix in the Monitoring and Control Network Remote Comparator Display Software Manual (reference 2) titled *Changing Status Message Text* for details about the format of the MCNRCD.CFG file.

7.3 Inverted Select A Example

For this example, assume we have the same system as in section 7.2, but we need to changed the system so that the TX 1 Select relay is normally closed (so that if the power fails, the TX 1 Select relay will be engaged). Figure 8 shows this modified system drawing.

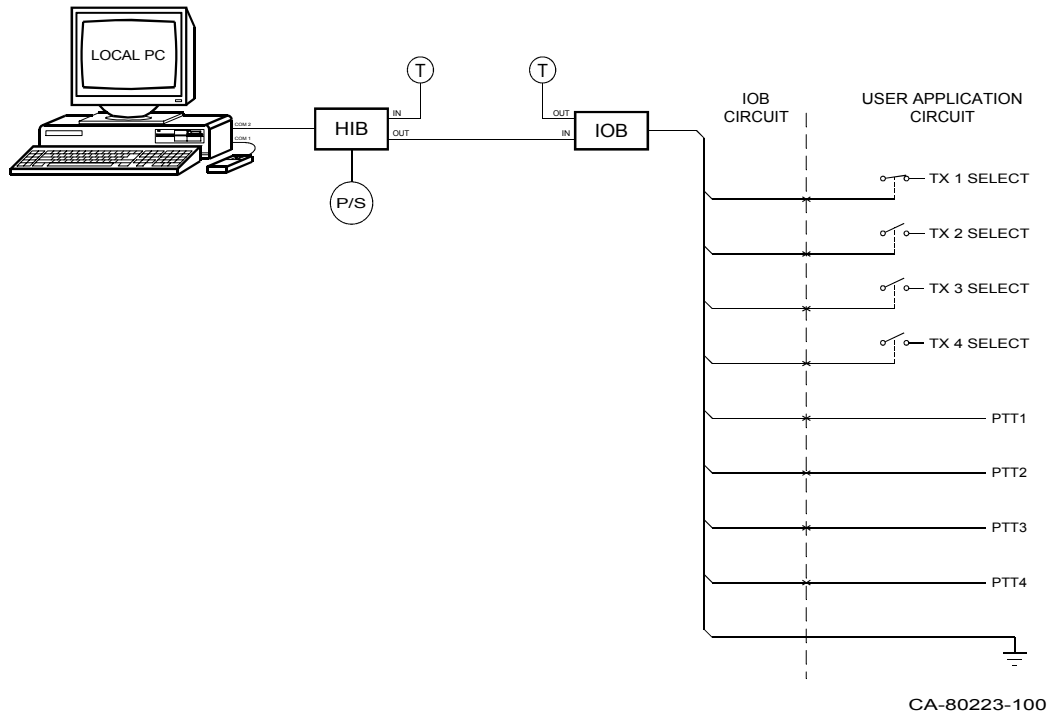

Figure 8 - Inverted Select A Example

Because the Select 1A output is connected to a normally closed relay, we need the Select 1A output to operate as an active high output instead of active low. The Select 1A output should be high when the Select 1A output is not the selected output and low when the Select 1A output is the selected output. The OPTION switch position 3 needs to be placed in the UP position to enable the inverted Select A output mode (the module must be reset or power cycled after the switch is changed).

The system in Figure 8 operates the same as the system in section 7.2

7.4 Sub-category Example

Figure 9 shows a system that uses a single IOB module to monitor two different types of input devices. One set of input devices are alarm input and the other set of input devices are control inputs.

Because the IOB is monitoring two different input device types, we need to divide the IOB's status text category in the MCNRCD.CFG file into two sub-categories so that meaningful status messages can be displayed for either type of input device. Before defining our custom text messages, let's look at the configurations for the two I/O groups. This is shown in Figure 9.

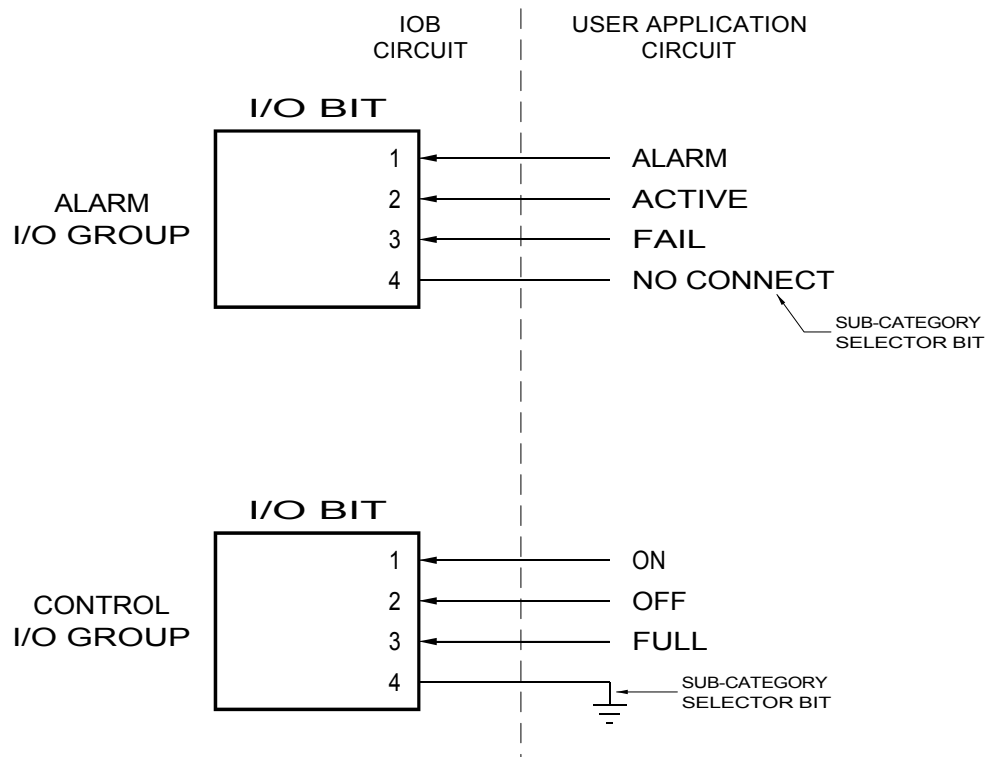

CA-80275-100

Figure 9 - Alarm and Control I/O Group Configurations

Since there are two sub-categories defined in this system, we need to reserve one of the I/O bits for the sub-category selector. Figure 9 shows that I/O bit 4 (FAIL) is reserved for the sub-category selector. Because I/O bit 4 is reserved, we cannot use any IOB I/O pins that correspond to I/O bit 4 (see Table 16) as general purpose I/O pins. Table 21 shows how the sub-category selector bit operates.

I/O Bit 4	Sub-category
0	Alarm
1	Control

Table 21 - Sub-category Selection

When I/O bit 4 is inactive (the input is floating), the Alarm sub-category text is selected and when it is active (the input is tied to ground), the Control sub-category is selected.

Using the I/O group definitions shown in Figure 9, we can create a custom text table for all possible input value field combinations. Table 22 shows the custom text messages and the corresponding input value fields.

Input Value Field	Active I/O Bit Combinations	Custom Text
00	-	
01	1	Alarm
04	2	Active
05	2 + 1	Act/Alrm
10	3	Fail
11	3 + 1	Fail
14	3 + 2	Fail
15	3 + 2 + 1	Fail
40	4	
41	4 + 1	On
44	4 + 2	Off
45	4 + 2 + 1	Error
50	4 + 3	Full
51	4 + 3 + 1	Full/On
54	4 + 3 + 2	Full/Off
55	4 + 3 + 2 + 1	Error

Table 22 - Custom Text for Sub-category System

From this table we can now create our custom status text category in the MCNRCD.CFG file. Refer to the appendix in the Monitoring and Control Network Remote Comparator Display Software Manual (reference 2) titled *Changing Status Message Text* for details about the format of the MCNRCD.CFG file.

8. Troubleshooting

This table is a list of troubleshooting tips specific to the IOB module. For additional troubleshooting tips, refer to the troubleshooting section found in the Monitoring and Control Network System Manual (reference 1).

Due to the high percentage of surface-mount components the IOB is treated as a field replaceable unit. If any system problems are the result of a malfunctioning IOB unit, the entire unit must be replaced and returned for repair.

PROBLEM	CAUSE
ERR LED is ON	Verify that the IOB's Group and Module switches are set to valid numbers.
The wrong status messages are being displayed for my custom category	Verify that the application circuits are connected to the proper IOB pins and that the input value fields of your MCNRCD.CFG file match your I/O bit assignments for the application circuits.
I have defined sub-categories in my system, but the status messages being displayed are not correct	Verify that the sub-category selector pins are set to the proper state (inactive pins should be left as no connect, and active pins should be tied to ground).