

***MCN Monitoring and Control Network
Comparator Display System***

***CommandSTAR Lite Host Interface Module
CHIB
Hardware Reference Manual***

S2-60994-100

NOTE: This module must be configured before being installed in your system.
Refer to section 4 for configuration and section 8 for addressing.

FCC Statement

This equipment has been tested and found to comply with the limits for a Class A digital device, pursuant to Part 15 of the FCC Rules. These limits are designed to provide reasonable protection against harmful interference when the equipment is operated in a commercial environment. This equipment generates, uses, and can radiate radio frequency energy and, if not installed and used in accordance with the instruction manual, may cause harmful interference to radio communications. Operation of this equipment in a residential area is likely to cause harmful interference in which case the user will be required to correct the interference at his own expense.

Warning: Changes or modifications to this unit not expressly approved by the party responsible for compliance could void the user's authority to operate the equipment.

DOC Statement

This Class A digital apparatus meets all requirements of the Canadian Interference-Causing Equipment Regulations.

Cet appareil numérique de la classe A respecte toutes les exigences du Règlement sur le matériel brouilleur du Canada.

Computer Software Copyrights

This manual describes products that include copyrighted CTI Products, Inc. computer programs in semiconductor memory. CTI Products, Inc. reserves all rights for these programs, including the exclusive right to copy or reproduce the copyrighted computer programs in any form. No copyrighted computer program contained in products described in this manual may be copied, reproduced, decompiled, disassembled, or reversed engineered in any manner without express written permission of CTI Products, Inc. The purchase of products from CTI Products, Inc. shall not be deemed to grant either directly or by implication, estoppel, or otherwise, any license under the copyrights, patents, or patent applications of CTI Products, Inc., except for the normal non-exclusive, royalty fee license to use that arises by operation of law in the sale of the product.

Information contained in this document is subject to change without notice and does not represent a commitment on the part of CTI Products, Inc.

No part of this manual may be reproduced or transmitted in any form or by any means, electronic or mechanical, including photocopying and recording, for any purpose without the written permission of CTI Products, Inc.

Copyright 1995-2002, CTI Products, Inc. All rights reserved.

MCN, CHIB, CIB, and AIB are trademark of CTI Products, Inc.
Astrotac and CommandSTAR Lite are trademarks of Motorola.
Other trademarks referenced are properties of their respective owners.



CHIB Hardware Reference CTI Products, Inc.

Standard Limited Hardware Warranty

LIMITED WARRANTY. Equipment manufactured by CTI Products, Inc. is warranted to be free from defects in material and workmanship for a period of ONE (1) YEAR from date of shipment to original purchaser. Under this warranty, our obligation is limited to repairing or replacing any equipment proved to be defective by our inspection within one year of sale to the original purchaser. This warranty shall not apply to equipment which has been repaired outside our plant in any way, so as to, in the judgment of CTI Products, Inc. affect its stability or reliability, nor which has been operated in a manner exceeding its specifications, nor which has been altered, defaced, or damaged by lightning.

CUSTOMER REMEDIES. In the event of a defect, malfunction, or failure to conform to specifications established by the seller during the period shown, the customer shall call CTI Products, Inc. to obtain a Return Authorization Number and return the product or module, shipping and insurance prepaid. CTI Products, Inc., will then at its option, either repair or replace the product or module and return it, shipping prepaid, or refund the purchase price thereof. On-site labor at the purchaser's location is not included in this warranty.

EQUIPMENT NOT MANUFACTURED BY CTI Products, Inc. Equipment not manufactured by CTI Products, Inc. is excluded from this warranty, but is subject to the warranty provided by its manufacturer, a copy of which will be supplied to you upon specific written request.

NO OTHER WARRANTIES. The foregoing constitutes the sole and exclusive remedy of the buyer and exclusive liability of CTI Products, Inc., AND IS IN LIEU OF ANY AND ALL OTHER WARRANTIES EXPRESSED OR IMPLIED OR STATUTORY AS TO MERCHANTABILITY, FITNESS FOR PURPOSE SOLD, DESCRIPTION, QUALITY, PRODUCTIVENESS OR ANY OTHER MATTER.

NO LIABILITY FOR CONSEQUENTIAL DAMAGES. WITHOUT LIMITING THE FOREGOING, IN NO EVENT SHALL CTI PRODUCTS, INC. OR ITS SUPPLIERS BE LIABLE FOR ANY DAMAGES WHATSOEVER (INCLUDING, WITHOUT LIMITATION, SPECIAL, INCIDENTAL OR CONSEQUENTIAL DAMAGES OR FOR LOSS OF BUSINESS PROFITS, BUSINESS INTERRUPTION, LOSS OF BUSINESS INFORMATION, OR OTHER PECUNIARY LOSS) ARISING OUT OF THE USE OF OR INABILITY TO USE CTI PRODUCTS, INC. EQUIPMENT BY PURCHASER OR OTHER THIRD PARTY, WHETHER UNDER THEORY OF CONTRACT, TORT (INCLUDING NEGLIGENCE), INDEMNITY, PRODUCT LIABILITY OR OTHERWISE, EVEN IF CTI PRODUCTS, INC. HAS BEEN ADVISED OF THE POSSIBILITY OF SUCH DAMAGES OR LOSSES. IN NO EVENT SHALL CTI PRODUCTS, INC.'S, LIABILITY EXCEED THE TOTAL AMOUNT PAID BY PURCHASER FOR THE EQUIPMENT GIVING RISE TO SUCH LIABILITY.

CTI Products, Inc.
1211 W. Sharon Rd.
Cincinnati, OH 45240

If you have questions about the MCN comparator display system, call us at:
(513) 595-5900. (8:30 to 5:00 Eastern)

1. INTRODUCTION 1

1.1 REFERENCE DOCUMENTS 1

1.2 MODEL NUMBER..... 1

2. THEORY OF OPERATION 2

2.1 STATUS INDICATIONS 2

2.2 COMPARATOR CONTROLS 3

2.3 VOTE HOLD FEATURE 3

2.4 CONSOLE LED BLANK FEATURE 3

3. SPECIFICATIONS 4

4. OPTION SWITCHES 5

4.1 FRONT PANEL SWITCHES 5

4.2 REAR PANEL SWITCHES 6

5. CONNECTORS 7

6. LEDES..... 8

7. CONSOLE INTERCONNECTION 9

7.1 RS-232 CONNECTIONS WITH EXTERNAL CONVERTER 9

8. MCN ADDRESSING WITH CHIB MODULES..... 10

8.1 AIB OR CIB ADDRESSING 10

8.2 CHIB ADDRESS SETTING (GROUP & MODULE SWITCHES) 10

8.3 MCN SYSTEM EXPANSION 11

9. CONSOLE CONFIGURATION / MAPPING..... 12

10. REMOTE OPERATION..... 14

11. MOUNTING..... 15

12. TROUBLESHOOTING 16

Manual Revisions

Revision	Date	Description
100	10/12/2002	Initial Release

1. Introduction

The CommandSTAR Lite Host Interface Module (CHIB) is a member of the Monitoring and Control Network (MCN™) family of **User Interface Modules**. Hardware specifications and configuration information are described in this manual.

The CHIB module connects to a CommandSTAR Lite Console. The CHIB module is used with the MCN RCD software and a Comparator I/O Module (such as a CIB or AIB) to create a comparator display system on the CommandSTAR Lite console. For status display, the CHIB module maps the Vote, Receive, Disable, and Fail indications to the console LEDs. For control, the CHIB maps the Force Vote and Disable buttons on the console to the corresponding function on the Comparator I/O Module (AIB or CIB).

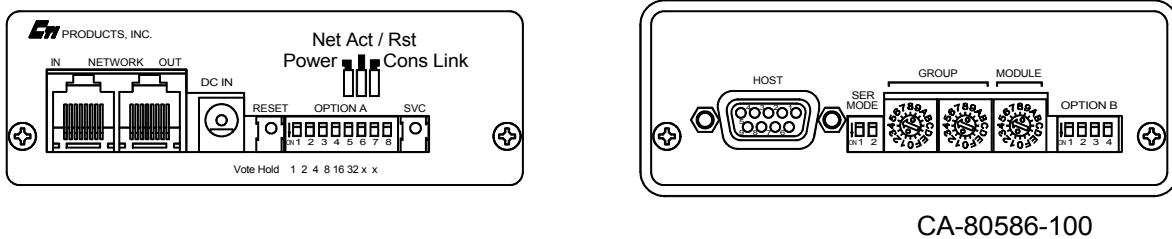

Figure 1 - CHIB Front and Rear View

1.1 Reference Documents

1. Monitoring and Control Network Comparator Display System Manual
Part Number S2-60425
2. AIB Hardware Reference Manual
Part Number S2-60399
3. CIB Hardware Reference Manual
Part Number S2-60426

1.2 Model Number

Model Number	Description
S2-60950-100	CHIB Module with RS-232 Interface Requires external RS-232 to RS-485 converter

2. Theory of Operation

The CHIB module does not provide any direct monitoring or control functions. Its purpose is to bridge the MCN network to the CommandSTAR Lite console.

The CHIB module emulates a series of I/O modules on the CommandSTAR Lite's I/O communications bus. Since the console's I/O bus is RS-485, an RS-232 to RS-485 converter is required between the CHIB and the console.

The CHIB supports multiple baud rates from 9600 baud up to 115.2K baud, selectable from the rear panel.

The CHIB module can communicate with only one Comparator I/O module (CIB or AIB). It is limited to the following number of receivers:

CHIB module operating with AIB Module: 14 Receivers

CHIB module operating with CIB Module: 8 Receivers

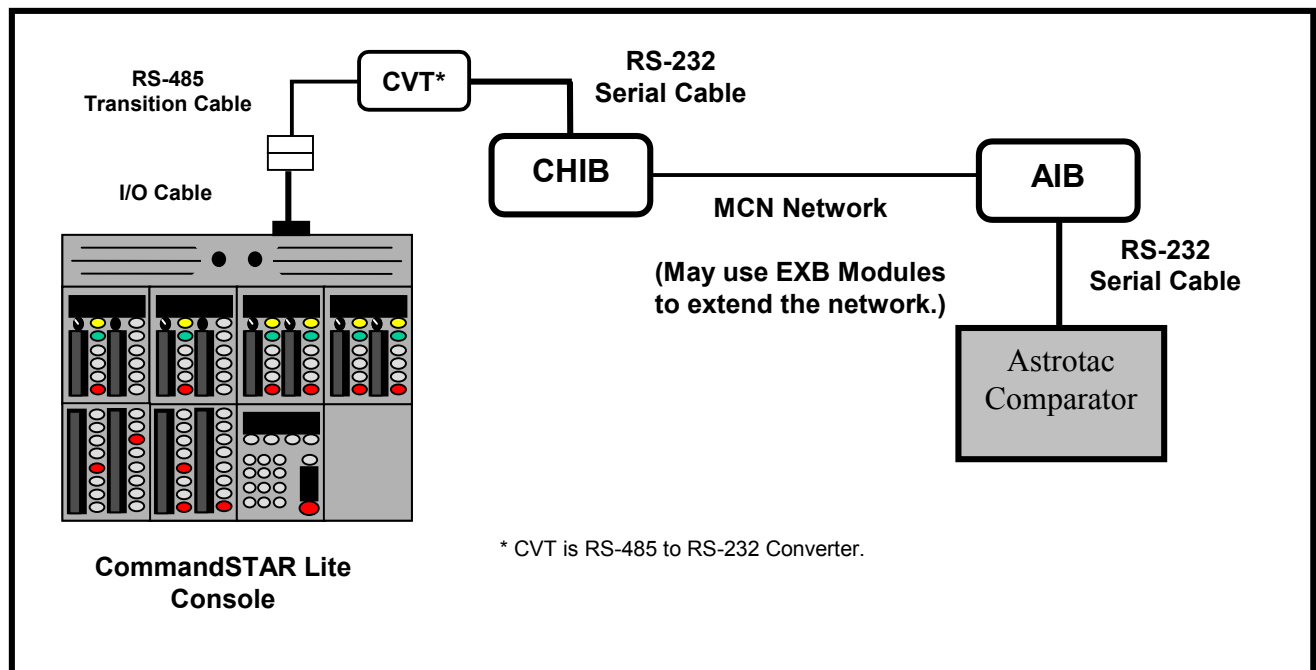

Figure 2 Typical System

2.1 Status Indications

The CHIB maps the Voted, Receiving, Disabled and Failed indications from the comparator to LEDs on the CommandSTAR Lite console.

The comparator generates the status signals. They are passed through the AIB or CIB module, through the MCN network, through the CHIB, the 485 converter, and into the console.

2.2 Comparator Controls

The CHIB maps buttons on the console to the Force Vote and Disable controls on the comparator. The CHIB forwards the messages on to the AIB or CIB, which then pass the signals or messages to the comparators.

The CHIB module does not provide direct feedback to the console operator on its own. Control feedback (the Voted or Disabled LED) comes from the comparator as described in Status Indications, above.

2.3 Vote Hold Feature

The Vote Hold feature allows an extended Vote Indication on the console. This provides the operator an indication of which site the last call came from. When all Vote signals go inactive, the CHIB will hold the last voted indication ON for the period of time specified on the Vote Hold Time switches.

If a new site votes during the Hold Time, the CHIB will display the new site, and will re-start the hold Time at the end of that transmission.

Vote Hold times are switch selectable from 0 (off) to 63 seconds, in increments of 1 second.

2.4 Console LED Blank Feature

If the CHIB loses communications with the AIB or CIB for a period of about 20 seconds, it will turn off all console LEDs that are mapped to it. This indicates that communications is lost. It will set the console LEDs to their proper state when communications with the AIB or CIB is reestablished.

3. Specifications

Size	5.5" x 4.2" x 1.5" (140 x 107 x 38 mm)
Weight	16 oz (455 gm)
Temperature	0 - 50 °C
Humidity	10 - 95% non-condensing
Module Power	10 - 32 VDC / 2 Watts max.
Serial Connector	9 pin D-SUB, female
Serial Interface	RS-232C
Baud Rate	9600, 14.4K, 19.2K, 38.4K, 57.6K, 115.2K
Network Connector	(2) RJ-45 (1 in, 1 out)
Network Protocol	MCN
Connects to:	1 AIB or 1 CIB (at address 00:0)
Safety Approvals	UL 1950 CSA 1950 EN 60950-1992
Emissions Compliance	FCC Part 15, Class A DOC Class A EN55022
Susceptibility Compliance	IEC 801-2 IEC 801-3 IEC 801-4 EN50082-1

Table 1 - Module Specifications

4. Option Switches

Five sets of option switches are provided for module configuration.

4.1 Front Panel Switches

The front panel switch functions are shown below:

SWITCH OPTION A	MODULE DESCRIPTION	DEFAULT
position 1	Vote Hold Time 1 Sec	UP
position 2	Vote Hold Time 2 Sec	UP
position 3	Vote Hold Time 4 Sec	UP
position 4	Vote Hold Time 8 Sec	UP
position 5	Vote Hold Time 16 Sec	DOWN
position 6	Vote Hold Time 32 Sec	DOWN
position 7	Not Connected	DOWN
position 8	Not Connected	DOWN

Table 2 - CHIB Front Panel Option A Switches

The Vote Hold Time is the sum of all the Active (Up) Vote Hold Time switches. Default is 15 seconds. Setting all switches Down will disable Vote Hold.

The Vote Hold Time switches are read in real-time and will take effect on the next active Vote signal.

4.2 Rear Panel Switches

The rear panel switches are read by the CHIB only upon reset. The module must be power cycled or reset after these switches are set so that the options will take effect.

SWITCH	MODULE DESCRIPTION	DEFAULT
SER MODE position 1	Reserved Must be Up	UP
position 2	Reserved Must be Up	UP
GROUP Hex Rotary	unit address setting refer to text	Derived from Serial Number -- See Text
MODULE Hex Rotary	unit address setting refer to text	Derived from Serial Number -- See Text
OPTION B position 1	baud rate select 0 (see Table 4)	DOWN
position 2	baud rate select 1 (see Table 4)	UP
position 3	baud rate select 2 (see Table 4)	UP
position 4	Reserved	DOWN

Table 3 - CHIB Rear Panel Option Switches

The Group and Module selector switches are used to set the unit address during module installation. See the Address Setting section of this manual for more information about setting these switches.

Baud Rate	Option B SW 1 baud rate select 0	Option B SW 2 baud rate select 1	Option B SW 3 baud rate select 2
9600 bps	UP	UP	DOWN
14.4 kbps	DOWN	DOWN	DOWN
19.2 kbps	DOWN	DOWN	UP
38.4 kbps	UP	DOWN	UP
57.6 kbps **	DOWN	UP	UP
115.2 kbps	UP	UP	UP

Table 4 - Baud Rate Selector Switches

** Factory Default

5. Connectors

The **NETWORK IN/OUT** ports on the front of the CHIB are used to connect the CHIB with other MCN modules. These ports carry both the network data signals and the DC power for power distribution with other modules. Table 5 gives the pinout for these connectors. Figure 3 shows the location of pin 1 for each port.

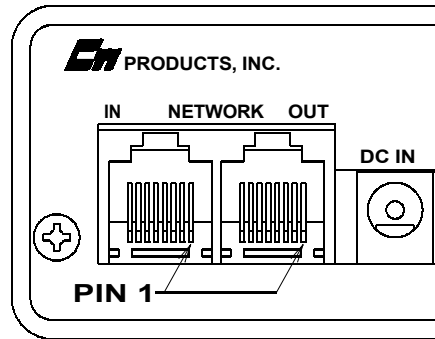

CA-80068-100

Figure 3 - Network IN/OUT Ports

Pin	Function
1	DATA +
2	DATA -
3	+ POWER
4	No Connect
5	No Connect
6	- POWER
7	- POWER
8	+ POWER

Table 5 - Network Connector Pinout

The **DC IN** port provides the primary power connection to the module. Power is distributed through the **NETWORK OUT** connector to provide power to the **NETWORK IN** connector of the MCN unit it is connected to. Each power supply can power up to four units total. See reference 1 for complete details of connections to the network and DC IN connectors.

6. LEDs

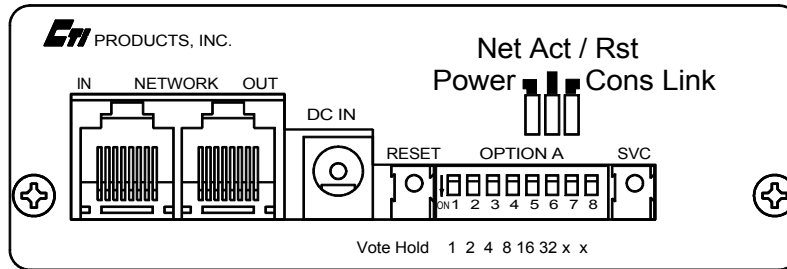

There are 3 front-panel LEDs:

Power LED (Green)

Lit when proper power is applied.

Blinks if the voltage is low.

Network Activity / Reset (Red)

This LED is active upon reset. It also blinks when traffic is received from the AIB/CIB and when messages (button presses) are received from the console.

Console Link (Yellow)

This LED blinks rapidly during the first communications with the console, as the console and CHIB module are synchronizing. It then stays on as long as the console link is okay. If the link to the console drops, this LED goes out.

7. Console Interconnection

7.1 RS-232 Connections with External Converter

The CommandSTAR Lite console requires an RS-485 converter between the CHI module and the console. The following tables show the cabling that is required when using the CHIB module in RS-232 mode. The pinouts are based upon the following converter:

- B&B 485CSP-2 RS-232 to RS-485 Converter

CHIB HOST Connector DE9-female Signal Name	Serial Cable DE9-male	Dir.	Serial Cable DB25-male	B&B 485CSP-2 RS-485 Converter Signal
DCD	1	←	8	DCD
RXD	2	→	2	TCD
TXD	3	←	3	RXD
DTR	4	←	6	DSR
Ground	5	--	7	Ground
DSR	6	→	20	DTR
RTS	7	←	5	CTS
CTS	8	→	4	RTS
RI	9	←	22	RI
Chassis Gnd	shell	--	shell	FG

Table 6 - RS-232 Connections CHIB to Converter Cable S2-60445

B&B Converter Signal	RS485 Transition Cable			CS Lite I/O Cable		Command STAR Lite Signals
	B&B Screw Term.	Dir.	DB-25 P	DB-25 S	HD-15P	
TDA (-)	1	→	15	15	13	RX-
TDB (+)	2	→	3	3	8	RX+
RDA (-)	3	←	14	14	15	TX-
RDB (+)	4	←	2	2	10	TX+
Gnd	5	--	5	5	7	Ground

Table 7 - RS-485 Connections B&B Converter to CommandSTAR Lite Console

8. MCN Addressing with CHIB Modules

Like any other module in the MCN family, the CHIB module must have a unique address on the network.

8.1 AIB or CIB Addressing

Version 100 of the CHIB module uses a fixed address for its companion AIB or CIB module. It always looks for that module at Group 00 : Module 0.

The AIB or CIB Module that is used with the CHIB module must be addressed at:

Group 00 Module 0.

8.2 CHIB Address Setting (Group & Module Switches)

The CHIB module is a User Interface module in the MCN system. The MCN System Manual and System Planner suggest that all User Interface modules be assigned to addresses starting at Group 80. This recommendation is only for convenience of planning your address map. The only real limitation on a CHIB address is that it must be unique. Therefore, in a system with just an AIB (or CIB) and a number of CHIB modules, the AIB or CIB would be addressed at 00:0 and the CHIBs would all be set to different addresses.

Some remote applications require multiple consoles to connect to a remote AIB or CIB using EXB modules. To ensure unique CHIB addressing in these applications, we ship the CHIB modules pre-addressed. The addresses are unique, and are based upon the CHIB serial number. The addresses are printed on the Serial Number tag. The addresses start at Group:Module 00:1 and are incremented sequentially as shown:

Serial Number	Group	Module
1001	01	1
1002	01	2
1003	01	3
...
1009	01	9
1010	01	A
1011	01	B
1012	01	C
1013	01	D
1014	01	E
1015	01	F
1016	02	0
1017	02	1

If these addresses conflict with your system's address map, simply change the CHIB addresses.

8.3 MCN System Expansion

The CHIB module and its companion AIB/CIB module can reside on an MCN network with other devices, as long as all MCN units have unique addresses and the AIB/CIB is addressed at 00:0. It is subject to the same limitations of a maximum of 20 CIB/AIB/IOB modules and a maximum of 64 modules total on one physical network.

Multiple CHIB modules can reside on the same MCN network. All CHIBs will talk to the same AIB or CIB, and all will give the users parallel status and control functions. One operator can disable a site and an operator at a different console can re-enable the site later.

A CHIB can talk with only one AIB or CIB module. Since CHIB version 100 looks for the AIB or CIB at a fixed address, they cannot be set to talk to other AIBs or CIBs that are on the network.

Other CIBs and AIBs can reside on the MCN network, along with PCs using HIBs or PCLTA modules. The PCs can access all the AIB or CIB modules (including the one that the CHIB talks to).

9. Console Configuration / Mapping

The CHIB module emulates 5 CommandSTAR Lite I/O boxes. The receiver status and control signals are mapped to the I/O Box points as shown below. Typical programming in CSDM Lite is shown in the rightmost two columns. Use I/O Type H. LEDs are programmed in pairs.

Rx	Signal	Button/LED	I/O Box			Programming	
			Address	Relay ID	Opto ID	Output	Input
1	Disable	Button	30H	0		1	
1	Force Vote	Button	30H	1		2	
1	Disabled	LED	30H		0		1
1	Receive	LED	30H		1		1
1	Failed	LED	30H		2		2
1	Voted	LED	30H		3		2
2	Disable	Button	30H	2		3	
2	Force Vote	Button	30H	3		4	
2	Disabled	LED	30H		4		3
2	Receive	LED	30H		5		3
2	Failed	LED	30H		6		4
2	Voted	LED	30H		7		4
3	Disable	Button	30H	4		5	
3	Force Vote	Button	30H	5		6	
3	Disabled	LED	30H		8		5
3	Receive	LED	30H		9		5
3	Failed	LED	30H		10		6
3	Voted	LED	30H		11		6
4	Disable	Button	31H	0		7	
4	Force Vote	Button	31H	1		8	
4	Disabled	LED	31H		0		7
4	Receive	LED	31H		1		7
4	Failed	LED	31H		2		8
4	Voted	LED	31H		3		8
5	Disable	Button	31H	2		9	
5	Force Vote	Button	31H	3		10	
5	Disabled	LED	31H		4		9
5	Receive	LED	31H		5		9
5	Failed	LED	31H		6		10
5	Voted	LED	31H		7		10
6	Disable	Button	31H	4		11	
6	Force Vote	Button	31H	5		12	
6	Disabled	LED	31H		8		11
6	Receive	LED	31H		9		11
6	Failed	LED	31H		10		12
6	Voted	LED	31H		11		12
7	Disable	Button	32H	0		13	
7	Force Vote	Button	32H	1		14	
7	Disabled	LED	32H		0		13
7	Receive	LED	32H		1		13
7	Failed	LED	32H		2		14
7	Voted	LED	32H		3		14

Rx	Signal	Button/LED	I/O Box			Programming	
			Address	Relay ID	Opto ID	Output	Input
8	Disable	Button	32H	2		15	
8	Force Vote	Button	32H	3		16	
8	Disabled	LED	32H		4		15
8	Receive	LED	32H		5		15
8	Failed	LED	32H		6		16
8	Voted	LED	32H		7		16
9	Disable	Button	32H	4		17	
9	Force Vote	Button	32H	5		18	
9	Disabled	LED	32H		8		17
9	Receive	LED	32H		9		17
9	Failed	LED	32H		10		18
9	Voted	LED	32H		11		18
10	Disable	Button	33H	0		19	
10	Force Vote	Button	33H	1		20	
10	Disabled	LED	33H		0		19
10	Receive	LED	33H		1		19
10	Failed	LED	33H		2		20
10	Voted	LED	33H		3		20
11	Disable	Button	33H	2		21	
11	Force Vote	Button	33H	3		22	
11	Disabled	LED	33H		4		21
11	Receive	LED	33H		5		21
11	Failed	LED	33H		6		22
11	Voted	LED	33H		7		22
12	Disable	Button	33H	4		23	
12	Force Vote	Button	33H	5		24	
12	Disabled	LED	33H		8		23
12	Receive	LED	33H		9		23
12	Failed	LED	33H		10		24
12	Voted	LED	33H		11		24
13	Disable	Button	34H	0		25	
13	Force Vote	Button	34H	1		26	
13	Disabled	LED	34H		0		25
13	Receive	LED	34H		1		25
13	Failed	LED	34H		2		26
13	Voted	LED	34H		3		26
14	Disable	Button	34H	2		27	
14	Force Vote	Button	34H	3		28	
14	Disabled	LED	34H		4		27
14	Receive	LED	34H		5		27
14	Failed	LED	34H		6		28
14	Voted	LED	34H		7		28
15	Disable	Button	34H	4		29	
15	Force Vote	Button	34H	5		30	
15	Disabled	LED	34H		8		29
15	Receive	LED	34H		9		29
15	Failed	LED	34H		10		30
15	Voted	LED	34H		11		30

10. Remote Operation

Because of the protocol between the CommandSTAR Lite console and the CHIB module, modem connection between the CHIB and the console is not supported. The CHIB must always be connected locally to the console (within the appropriate RS-485 or RS-232 distance limits).

If display and control of a remote comparator is required, this can be done with standard MCN EXB Network Extender Modules. These modules are available in the following versions:

Model	Description
S2-60602	MCN EXB Module with Internal 2W/4W Leased Line Modem Certified for US, Canada, and UK operation. Can also be used on private leased lines that are not subject to PTT approval requirements.
S2-60655	MCN EXB-SER Module with (2) RS-232 ports For use with external modems or digital channel banks.

The EXB modules would be inserted in the MCN network between the CHIB and the AIB or CIB.

11. Mounting

Please refer to reference 1, *Mounting Options*, for details of mounting the CHIB module.

CAUTION

Make sure that any mounting screws used to secure unit to a bracket do not protrude into the unit's enclosure more than 1/8 inches from the bottom surface of the unit.

Using a larger screw that touches the PC board inside the unit may damage the unit when it is powered. Doing so will void the unit's warranty.

12. Troubleshooting

This table is a list of troubleshooting tips specific to the CHIB module. For additional troubleshooting tips, refer to the troubleshooting section found in the *Monitoring and Control Network System Manual*, reference 1.

Due to the high percentage of surface-mount components, the CHIB is treated as a field replaceable unit. If any system problems are the result of a malfunctioning HIB unit, the entire unit must be replaced and returned for repair.

PROBLEM	CAUSE
Green Power LED Off	No Input DC Voltage. Check power supply and/or input network connection
Green Power LED Blinking	Input DC Voltage is too low (<10 VDC) Check power supply and/or input network connection
Net Act /Reset LED is on solid	Bad CHIB module
CONSOLE Link (Yellow) LED Off	CHIB and Console are not communicating. Possible Problems: <ol style="list-style-type: none"> 1. CHIB Baud Rate Switches 2. Console I/O Cable and/or RS-485 Transition Cable 3. RS485 Converter and/or power supply 4. RS-232 Cable from CHIB to RS485 converter 5. Bad CHIB 6. Bad Console <p>You can use the LEDs on the RS485 converter to help you troubleshoot this problem. You should see the console polling the CHIB on LED DS2. You should see the CHIB respond on LED DS1.</p>
No Status Updates, Force Votes or Disables	This could be anywhere in the system. <ol style="list-style-type: none"> 1. Check the power LEDs on all equipment. 2. On the CHIB module: Is the Console Link LED on? If not, see the section "<i>Console Link (Yellow) LED off.</i>" 3. Is the ACT LED on the AIB/CIB on? If not, see the section "<i>ACT LED on CIB or AIB is off.</i>" 4. Verify Address settings on CHIB and AIB/CIB 5. If using an AIB: Bad AIB Switch Settings

PROBLEM	CAUSE
	<p>Bad AIB to Astrotac cable Bad Astrotac</p> <p>5. If using a CIB Bad connections to the comparator Bad CIB</p> <p>6. Bad console I/O programming, firmware, or module</p>
<p>Status Updates Okay but no Force-Votes or Disables</p>	<p>Since status updates are okay, the links between the console and CHIB are okay. Also, the link between the AIB or CIB and the CHIB is okay (at least in the AIB/CIB to CHIB direction). <i>(Remember that switch presses must go through the entire system and then back to the console before the LED comes on.)</i></p> <p>Possible problems:</p> <p>1. Check to see if the ACT LED on CIB or AIB is off. - Disconnect all other possible CHIBs, HIBs, and IIBs from the AIB or CIB. (If any of these devices is accessing the AIB or CIB, the ACT LED will be on.) - If the ACT LED on the CIB or AIB is off, see the section labeled: <i>"If ACT LED on CIB or AIB is off"</i>.</p> <p>2. If using a CIB: Bad wiring to comparator Improper option switch setting on CIB Bad CIB</p> <p>3. If using an AIB: Bad AIB or Astrotac comparator</p>
<p>ACT LED on CIB or AIB is off</p>	<p>CHIB is not talking to the CIB or AIB. Possible Problems:</p> <p>1. Check MCN Network Connections</p> <p>2. Bad Address on AIB or CIB module (These <i>must</i> be set to 00:0.)</p> <p>3. Bad address on CHIB module (It <i>cannot</i> be set to 00:0.)</p> <p>4. There may be a duplicate address on a module in the system</p> <p>5. If using EXB-Serial units, possible data transmission problem from CHIB side to AIB/CIB side.</p> <p>6. Bad EXB units</p> <p>7. Bad CHIB, AIB, or CIB modules</p>
<p>Net Act /Reset LED blinks</p>	<p>This is a normal condition. This LED will blink when the CHIB sees updates from the AIB/CIB or when the console sends button</p>

PROBLEM	CAUSE
	<p>presses.</p> <p>If you disconnect both the network and the serial cable from the CHIB, you should see a flash on this LED once every 4-5 seconds. If you see a different pattern than this with both the cables disconnected, the CHIB is bad.</p>